



A. General Information

Project Name:	EDWI Project	Submitted Date:	5/21/2021
Requestor:	Nikole Helvey	Required Date:	5/21/2021
Decision Log No:	EDW-039		

B. High Level Statement of the Issue

The Enterprise Data Warehouse Implementation (EDWI) Project is seeking approval of the first major deliverable, PD-3: *High-Level Technical Design*.

PD-3: *High-Level Technical Design* provides an overview of the technical solution planned for the EDWI project. The plan includes the design of the solution framework, which serves as a single point of reference for systems and data. It also covers the high-level technical design of various components of the EDW solution including infrastructure, network, module integration approach, and user interface. The *High-Level Technical Design* presents the:

- Business View of the Solution - The business view of the EDW describes the business components of the solution. It provides a functional overview of the solution and the various components that support the day-to-day needs of the system's end users. This includes the access layer, security layer, presentation layer, business function layer, application layer, integration layer, data layer, and infrastructure layer.
- Technical View of the Solution - The technical view provides the relationship between various technical components of the solution, including data sources, data movement/flows, data storage and processing, information delivery, and information consumers.
- Infrastructure View of the Solution - The infrastructure view of the solution provides the underlying hardware components leveraged to support the technical and business components. Included within the infrastructure view is a representation of constructs used by the solution, such as clustering.
- Network View of the Solution - The network view of the solution provides a high-level view of interaction points between the solution and external systems; including inbound, outbound, and external connectivity from the EDW Amazon Web Services (AWS) solution.

The *High-Level Technical Design* also provides an overview of the solution components: the individual objects configured to provide specific services for the EDW solution. This includes:

- Data Integration - As the EDW solution is designed to be the single source of truth for Medicaid-related data in the organization, data integration becomes a critical part of the solution providing the mechanisms to integrate data from disparate sources. The source systems will use different methods for communicating with the EDW solution and will provide input in various formats. This includes data replication, ongoing data transfer, web services, data governance, and content management.



- Database Architecture - Databases are the key component of the EDW solution. The EDW solution includes various databases and data marts to fulfill the requirements of the FX EDWI Project. The EDW solution will include the following databases: Operational Data Store (ODS), Reporting Data Store, Analytic Data Store, Specialized Data Marts, and Content Management Data Store.
- Environment Configuration - The EDW solution contains five environments for the implementation and support of the EDWI project. These environments serve a different purpose and are aligned with the FX technical standards. Configuration of the various environments follows different timelines based upon the project schedule. The five environments are: Development, Systems Integration Test (SIT), User Acceptance Test (UAT), Production, and Disaster Recovery (DR).
- User Interaction - The end-user experience is a key component of any data and analytics solution. While it is critical to make information available to end users, it is also important to make it easy for end users to get the information they seek. The solution supports the various Agency personas identified for Business Intelligence and Data Analytics. The EDW solution also provides a single portal for all the reporting needs for the end user.
- Module Integration – During this design, development, and implementation (DDI) phase of the EDWI project, the EDW solution will integrate with FMMIS as a source module. To achieve FX Program goals, the EDWI team will work with the Agency and other stakeholders to integrate with future modules as they are implemented.

C. Decision Point(s)

Seeking ESC approval of the PD-3: *High-Level Technical Design* deliverable.

D. Considerations

Approving the summary of the PD-3: *High-Level Technical Design* serves as approval for this major deliverable.

E. Listing of Attached Supplemental Information

DOCUMENT TITLE	BRIEF DESCRIPTION
FX-EDWI-PD-3-High-Level-Design-ESC-Summary-100	Summary of the EDWI <i>High-Level Technical Design</i> document

F. Additional Background (as needed)

N/A

G. Are state funding (LBR) changes needed?

Yes

No



H. Are federal funding changes needed?

Yes

No

I. List any systems impacted by this decision

EDW solution

J. Referred by?

Yes (check all that apply)

No _____

Referred by:

FX Enterprise Program Management Office

FX Portfolio Management

FX Implementation Team

FX Executive Steering Committee

FX Technical Standards Committee

K. Decision Maker and Decision Date

Date of Decision:

Decision:

Decision Made By:

AHCA Secretary

Designee FX Executive Sponsor

Designee FX Director

Designee (other)

FX Executive Steering Committee



L. Next Steps

NEXT STEP	TARGET DUE DATE	ASSIGNED TO
With the approval of the High-level Tech Design, the EDW vendor can proceed to work on the detailed design for the EDW solution.	5/21/2021	NA

AHCA Florida Health Care Connections (FX)

PD-3: High-Level Technical Design

Version: 100

Date: April 28, 2021

Author: EDW Vendor

Submitted To: AHCA FX Program Administration Team





Revision History

DATE	VERSION	DESCRIPTION	AUTHOR
3/16/2021	001	PD-3: High-Level Technical Design Development Draft Version	Arvind Dubey
4/7/2021	002	PD-3: High-Level Technical Design Final Draft Version	Arvind Dubey
4/22/2021	003	PD-3: High-Level Technical Design Final Draft Version	Arvind Dubey
4/28/2021	100	PD-3: High-Level Technical Design Approved Final Version	Carol Williams

Modifications to the approved baseline version (100) of this artifact must be made in accordance with the FX Artifact Management Standards.

Quality Review History

DATE	REVIEWER	COMMENTS
3/16/2021	Don Hoag	Initial Quality Review Complete
4/7/2021	Don Hoag	Quality Review Complete
4/22/2021	Don Hoag	Quality Review Complete



Table of Contents

Section 1	Introduction	1
1.1	Background.....	1
1.2	Purpose	1
1.3	Scope Statement	1
1.4	Goals and Objectives.....	2
1.5	Referenced Documents	2
1.6	Assumptions and Dependencies.....	2
Section 2	Roles and Responsibilities	4
Section 3	High-Level Technical design	5
3.1	Business View	5
3.2	Technical View.....	7
3.2.1	Data Sources	8
3.2.2	Data Movement	8
3.2.3	Data Storage and Processing	10
3.2.4	Information Delivery	11
3.2.5	Information Consumers.....	12
3.3	Infrastructure View	12
3.4	Network View.....	14
3.4.1	Inbound.....	15
3.4.2	Outbound.....	17
3.4.3	External Connectivity	18
Section 4	Solution components	20
4.1	Data Integration	20
4.1.1	Data Replication	20
4.1.2	On-Going Data Transfer	21
4.1.3	Web-Services	22
4.1.4	Data Governance.....	23
4.1.5	Content Management	24
4.2	Database Architecture Overview.....	24



4.3 Environment Configuration..... 26

Section 5 User Interaction 29

5.1 Interaction Methods and Features..... 29

5.2 Personas 30

Section 6 Module Integration 31

Appendix..... 32

6.1 Appendix A 32

6.2 Appendix B 32

Table of Exhibits

Exhibit 1-1: Contract EXD091 Requirements 2

Exhibit 2-1: Roles and Responsibilities 4

Exhibit 3-1: Business View of EDW Solution 5

Exhibit 3-2: Technical View 7

Exhibit 3-3: Infrastructure View 13

Exhibit 3-4: Icons Used in the Infrastructure and Network View 14

Exhibit 3-5: Network View 15

Exhibit 3-6: Inbound Traffic 16

Exhibit 3-7: Outbound Traffic..... 17

Exhibit 3-8: Site-to-Site VPN 18

Exhibit 3-9: Equinix and Modules 19

Exhibit 3-10: IS/IP IAM and EDW Integration 20

Exhibit 4-1: AWS Data Migration Services 21

Exhibit 4-2: On-Going data Transfer..... 21

Exhibit 4-3: Representative Data Transformation Jobs..... 22

Exhibit 4-4: Metadata Management..... 24

Exhibit 4-5: Database Architecture Overview 25

Exhibit 4-6: SIT Connectivity 27

Exhibit 4-7: UAT and Production Connectivity 28

Exhibit 4-8: Deployment Path..... 28

Exhibit 5-1: Representative View of Front-End Entry to the Portal..... 30

Exhibit 5-2: Representative Personas 30



Section 1 INTRODUCTION

1.1 BACKGROUND

The Florida Agency for Health Care Administration (AHCA or Agency) is adapting to the changing landscape of healthcare administration and increased use of the Centers for Medicare and Medicaid Services (CMS) Medicaid Information Technology Architecture (MITA) to improve the administration and operation of the Florida Medicaid Enterprise. The current Florida Medicaid Enterprise is complex; it includes services, business processes, data management and processes, technical processes within the Agency, and interconnections and touchpoints with systems necessary for administration of the Florida Medicaid program that reside outside the Agency. The future of the Florida Medicaid Enterprise integration is to allow the Agency to secure services that can interoperate and communicate without relying on a common platform or technology.

The Florida Medicaid Management Information System (FMMIS) has historically been the central system within the Florida Medicaid Enterprise; functioning as the single, integrated system for claims processing and information retrieval. As the Medicaid program has grown more complex, the systems needed to support the Florida Medicaid Enterprise have grown in number and complexity.

The Medicaid Enterprise System (MES) Procurement Project was re-named Florida Health Care Connections (FX) in the summer of 2018. FX is a multi-year transformation to modernize the current Medicaid technology using a modular approach, while simultaneously improving overall Agency functionality and building better connections to other data sources and programs.

1.2 PURPOSE

The purpose of the PD-3: High-Level Technical Design is to provide the readers with an overview of the technical solution as it is planned for the Enterprise Data Warehouse Implementation (EDWI) project. The plan includes an approach to integration related to the scope of work defined in Contract EXD091. The plan also includes the design of the framework that serves as a single point of reference for integration management of modules, systems, and data. There are number of architecture diagrams used within this deliverable. To support better readability of these diagrams, a separate attachment with the diagrams is included with the deliverable.

1.3 SCOPE STATEMENT

The scope of this plan covers the high-level technical design of various components of the EDW solution including infrastructure, network, module integration approach, and user interface. This deliverable provides an overview of the components to provide readers with an understanding of individual solution components and their integration together. The table below lists the Contract EXD091 requirements met through this deliverable:



EDWI VENDOR EXD091	PD-3: HIGH-LEVEL TECHNICAL DESIGN DELIVERABLE SECTION
<p>Attachment I, B.3.F.8.c.1: Payment Deliverable Requirements – Contract Wide</p> <p>3) PD-3: High-Level Technical Design</p> <p>a) The Vendor shall develop and submit a High-Level Technical Design (PD-3), which includes an approach to integration related to the scope of work. The Plan shall include the Vendor’s design of framework which shall serve as a single point of reference for integration management of modules, systems, and data.</p>	<p>Section 3.3: Infrastructure View Section 3.4: Network View</p>

Exhibit 1-1: Contract EXD091 Requirements

1.4 GOALS AND OBJECTIVES

Goal #1 – The goal of this deliverable is to provide stakeholders with a high-level design of the EDW technical solution.

- Objective #1 – Provide a business view of the EDW solution.
- Objective #2 – Provide a technical view of the EDW solution.
- Objective #3 – Provide a network view of the EDW solution.
- Objective #4 – Provide the integration methods as it applies to the EDW solution.

1.5 REFERENCED DOCUMENTS

The list below provides documents that this deliverable references:

- The PD-3: High-Level Technical Design meets the criteria set forth in T-5: FX Technical Architecture, T-2: FX Information Architecture, and T-6: FX Technology Standards, with versions as of the date of the submission of this deliverable.
- The PD-3: High-Level Technical Design references the Contract EXD091.

1.6 ASSUMPTIONS AND DEPENDENCIES

The deliverable PD-3: High-Level Technical Design has been drafted with following considerations:

- This deliverable has been drafted with design elements as per the understanding of Contract EXD091. Further deliberation during requirements validation and design sessions may introduce changes in the design elements.
- Technology components identified in this deliverable are based on an understanding of the approach from discussions during ODS discovery sessions.



- Representation in this deliverable for network connectivity is based on the long-term solution for network integration.
- External module integration design and schedule will be finalized during the task order discussions with the Agency and the module vendor.
- The Agency decided to use Fast Healthcare Interoperability Resources (FHIR) as the FX Application Programming Interface (API) standard. Vendor modules and Integration Service/Integration Platform (IS/IP) will be responsible for enforcing the FHIR standards. The EDW solution will be able to consume and respond with data to the FHIR requests received through the FX Enterprise Service Bus (ESB).
- The EDW solution will receive obfuscated data in the lower environments (Development, System Integration Test (SIT), and User Acceptance Test (UAT)).
- The database architecture is based on the EDW Vendor's current understanding of the models, based on discussions held between the Agency, the SEAS vendor, and the EDW vendor.
- FMMIS and the Agency will identify a working solution to support this design, where required source data and environments are available following the baseline PD-2: Project Schedule.
- The number of users and types of users are in alignment as it is defined in Contract EDX091. The user count is 350 and these users will be associated with one of the personas from Data Viewers, Data Selectors, Data Retriever, Analyst, Data Scientist, and Advanced Analyst.
- This design is predicated on configurable elements of the FMMIS environment being available based on the PD-2: Project Schedule.
- This deliverable provides an overarching view of solution components; details will be captured in PD-9: System Design Document.
- The Content Management component, formerly referenced as SmartBox, has been renamed DocuEdge. Further references will only be made to DocuEdge.



Section 2 ROLES AND RESPONSIBILITIES

This section identifies the roles and responsibilities for all the stakeholders involved with this deliverable.

ROLE	RESPONSIBILITY
EDWI Contract Manager (AHCA)	<ul style="list-style-type: none"> ▪ Partner with the EDWI Deliverable Review Team Lead, EDW Deputy Project Director, and EDW SEAS Project Manager ▪ Act as liaison between the EDW Vendor and the Review Team Lead, providing written review comments from reviewers, as received, to the EDW Vendor ▪ Notify the SEAS Project Manager via dated email of acceptance/rejection of the deliverable ▪ Review contract management requirements and ensure adherence to contract requirements and deadlines ▪ Review and provide resolution to submitted impact assessments ▪ Coordinate with Stakeholders and provide approval for the deliverable
EDWI Project Manager (SEAS)	<ul style="list-style-type: none"> ▪ Participate in deliverable review discussions to avoid or resolve conflicts, risks, and issues ▪ Execute defined processes in alignment with the FX Enterprise Program Management Office (EPMO) ▪ Adhere to compliance requirements detailed in the FX Standards
EDWI Deputy Project Director (EDW Vendor)	<ul style="list-style-type: none"> ▪ Review draft version of the deliverable and provide feedback to the deliverable development team. ▪ Participate in deliverable discussions to avoid or resolve conflicts, risks, and issues ▪ Participate in deliverable meetings
EDWI Technical Manager	<ul style="list-style-type: none"> ▪ Develop the deliverable ▪ Remediate comments and feedback received from the EDW Deputy Project Director ▪ Update and remediate the deliverable based on review feedback from the reviewers ▪ Identify impacts of changes to the design ▪ Identify any changes that require an impact assessment

Exhibit 2-1: Roles and Responsibilities

Section 3 HIGH-LEVEL TECHNICAL DESIGN

As with any large and complex system implementation, a high-level technical design overview of the solution can have different visibility requirements depending on the level of information anticipated from the stakeholder’s perspective. In order to support these multiple views, this document has been categorized into four primary views: Business View, Technical View, Infrastructure View, and Network View.

3.1 BUSINESS VIEW

A business view of the EDW shows readers the business components of the solution. The purpose of this view is to provide a functional overview of the solution and various solution components that support the day-to-day needs of the system's end users. The figure below provides a business view of the EDW solution.

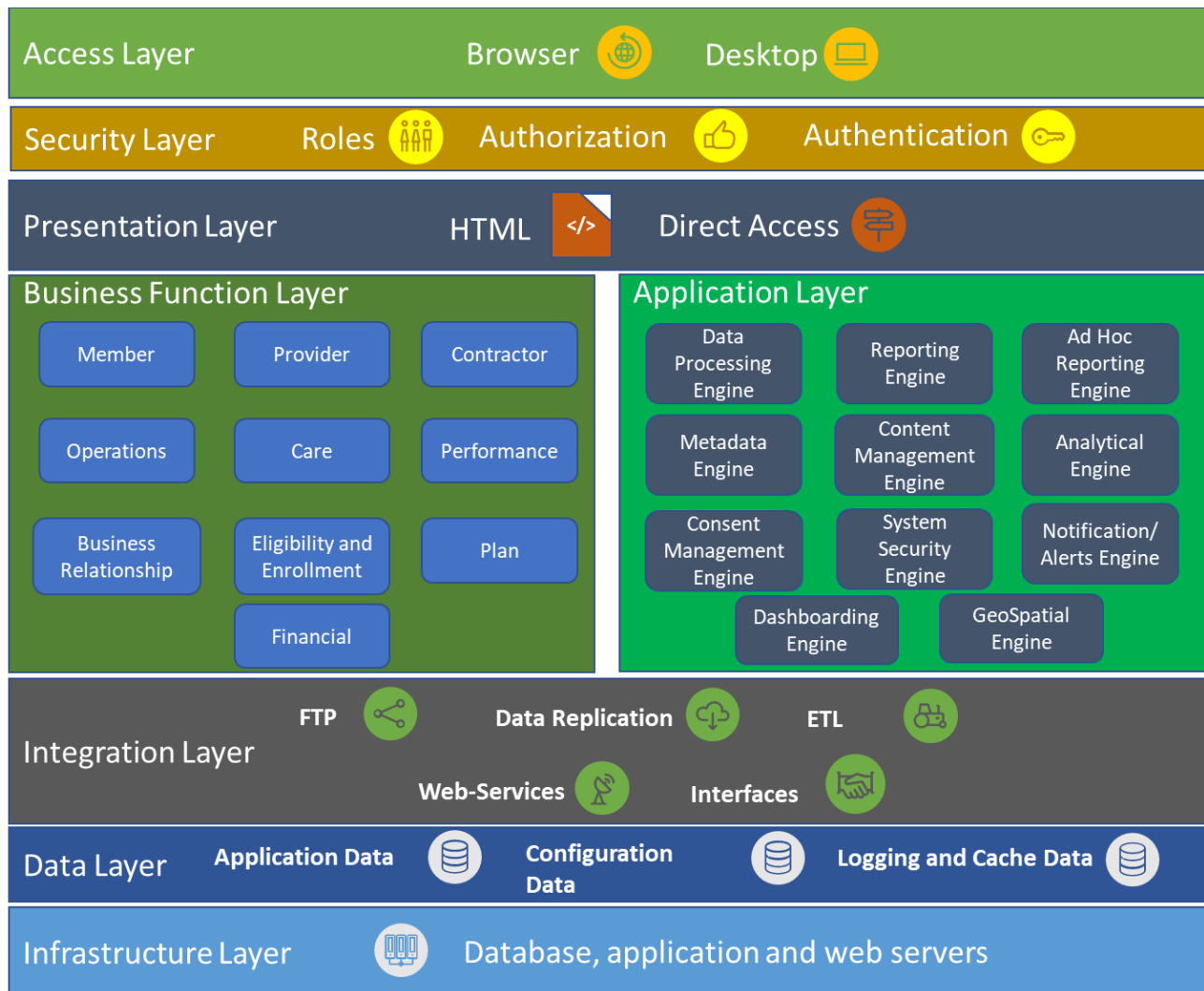

Exhibit 3-1: Business View of EDW Solution

The solution consists of the following components from a business architecture perspective:

- **Access Layer** – The Access Layer of the solution includes methods and components that end users use to interact with the system. This includes use of mobile or desktop-based browsers and desktop-based applications.
- **Security Layer** – The Security Layer of the solution constitutes components that are required for integration with enterprise solutions for authentication and authorization of system users. Management of system users is not restricted just to the application end user management, it also includes management of the accounts necessary for the backend processing, AWS account management and internal connectivity between various system components.
- **Presentation Layer** – The Presentation Layer consists of the means that are used by the access layer to interact with the solution. This includes the use of web-services, application HTML pages, and custom applications through direct connections.
- **Business Function Layer** – The Business Function Layer comprises the components deployed in the solution to support needs of individual business areas for the Agency, in alignment with the MITA definition of business functions for the Medicaid Enterprise Systems. Data needs for these individual functions are supported using underlying integration layer and application layer components of the solution.
- **Application Layer** – The Application Layer of the solution lists individual solution components performing specific functions, including features that are used in the background for data processing to the functions which are directly leveraged for the representation of information for the end users. These tools and engines are utilized to support the business functions identified in the business layer, by providing information in a consumable format to the end users, thus aiding in informed decision making processes.
- **Integration Layer** – The Integration Layer includes the components of the solution that are used to harvest and disseminate the data acquired from various source systems. These include an Extract, Transform, and Load (ETL) engine, data replication, web services (REST and SOAP) and Secure File Transfer Protocol (SFTP). This layer of the solution also includes any outbound interfaces where the EDW solution will be used to provide data to internal or external entities. One example is the T-MSIS submissions.
- **Data Layer** – This layer of the solution contains the backend data storage units, including the relational databases, file storage, and log components. The data layer of the solution consists of the following main database regions:
 - › Operational Data Store (ODS) – Operational Data Store is the primarily landing zone for the source data in its native form. Data will be replicated here and remodeled for downstream usage.
 - › Reporting Data Store (RDS) – This data store is used for operational reporting where pre-configured reports are generated using Cognos. This data store will also be available to authorized end users for dashboarding and ad hoc reporting for information needs that are closer to the transactional structures. In addition,

this data store also acts as the source for downstream data structures such as the Analytics Data Store (ADS), data marts and specialized data stores.

- › Analytics Data Store (ADS) – This data store is utilized by the authorized end users for advanced data analysis, ad hoc reporting, dashboarding and standard analytics. In addition, the power users have direct access to this data store for query based data analysis.
- › Data Marts – Data Marts are a logical segregation of the database objects to support business units for the Agency.
- › Specialized Data Stores – Specialized data stores serve a specific purpose for subject area-specific reports. For example, the Healthcare Effectiveness Data and Information Set (HEDIS) store provides reporting on HEDIS measures using information available in EDW solution.
- **Infrastructure Layer** – This layer reflects the actual hardware being used to support the application and primarily consists of a Linux-based cloud infrastructure. This also includes the networking components that are important for the integration of different solution components, as well as for end user access.

3.2 TECHNICAL VIEW

The technical view of the solution provides the relationship between various technical components of the solution. The figure below provides a graphical representation of the production system’s technical architecture of the EDW solution:

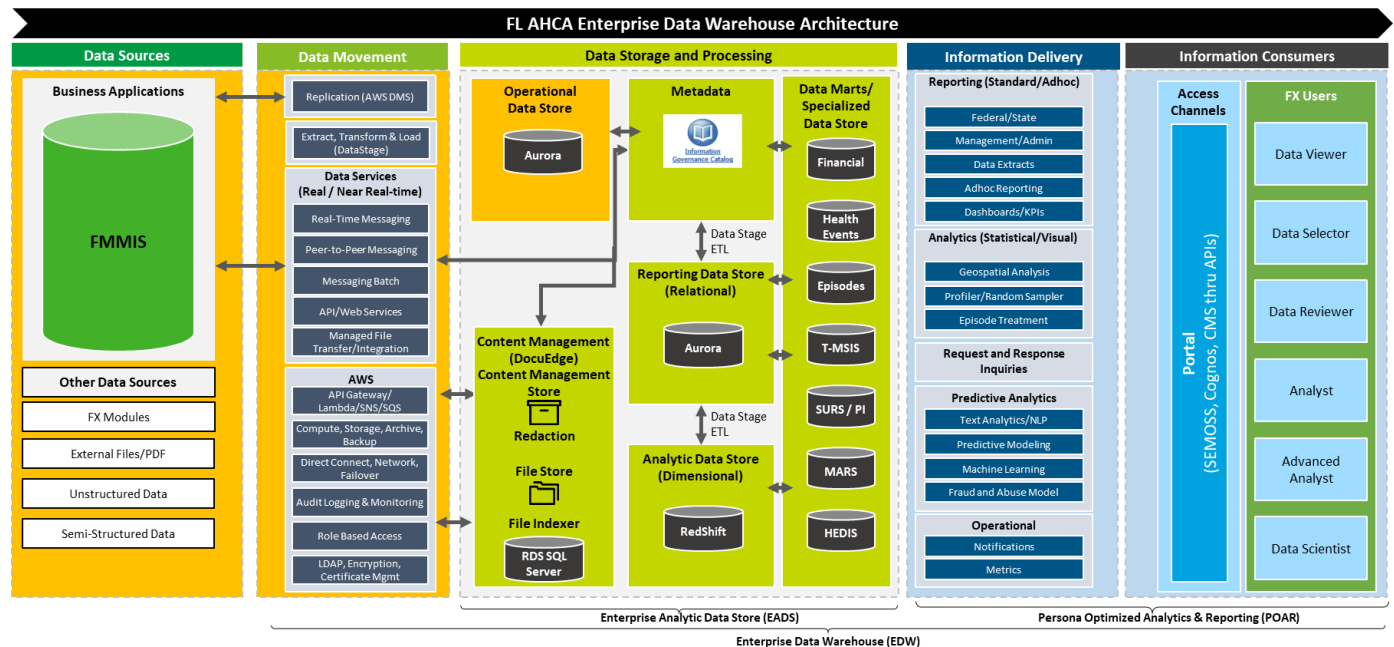

Exhibit 3-2: Technical View

The sections of the technical view are described in detail in the sections below.



3.2.1 DATA SOURCES

This group of components includes the source systems that are used for extracting and loading data to the EDW solution. For the Design, Development and Implementation (DDI) phase of the project, FMMIS Online Transaction Processing (OLTP) database is the source for the EDW. Future integration of modules may identify the need of additional sources, which will be discussed and designed in collaboration with the Agency and the vendor implementing the module. Listed below are applicable source systems for EDW:

- **FMMIS** – Legacy MMIS system will act as the only source for the EDW solution for the DDI phase of the project. The identified and agreed upon list of tables from the FMMIS OLTP schema will be replicated and will be used to populate various layers of the databases in the EDW solution.
- **Content Repositories** – Files stored in the Agency content repositories will be used to source the ingestion process for the EDW Content Management component.

Listed below are future data sources that may be ingested into the EDW:

- **FX Modules** – FX modules will be integrated into the ODS Evolution once the Agency has procured the services for specific modules.
- **Other Data Sources** – In the future, if the Agency identifies the need for external data elements that are required for reporting or other business needs of the solution, they will be integrated in the EDW solution via a new task order. These may include eligibility, pharmacy benefits, or enrollment sources.
- **External Files/PDF** – Like other data sources, if external files and PDFs are identified as a source for the Content Management solution, they will be identified and integrated during Enterprise Analytic Data Store (EADS) requirements validation sessions. These may include social determinants of health data, external files from the federal government, and drug reference information.
- **Unstructured Data** – Unstructured data like files, images, and Binary Large Objects may become potential sources for the EDW solution. These could include clinical health records and mobile health information.
- **Semi-Structured Data** – Semi-Structured Data like XML files that come from internet connected devices or federal/State clearing houses.

3.2.2 DATA MOVEMENT

This group of components includes methods and tools used for moving data from the source system to the EDW solution. Tools used for this group include Amazon Web Services (AWS) Data Migration Services, web-service calls (real/near real-time), messaging services, and batch mode data transfers using file transfer protocols. The list below defines individual blocks of the Data Movement process:

- **Replication** – In order to replicate the source data from FMMIS OLTP, the EDW solution leverages AWS Data Migration Services (DMS). AWS DMS connects with the



FMMIS source database and is used to provide near real-time data replication from the source system to the EDW ODS layer.

- **Extract, Transform, and Load (ETL)** – The EDW solution leverages IBM’s InfoSphere for the ETL process. ETL tools are primarily leveraged for processing the data received in batch mode. Files submitted through the SFTP process are processed into the ODS layer, as required, using the ETL engine.
- **Data Services** – The data services portion of the solution provides methods of data sharing through use of web-services (REST/SOAP). Listed below are the items available for data services in the solution and are deployed based on the project requirements and schedule:
 - › **Real-Time Messaging** – This function of the solution uses message queues to provide real-time communication between various systems.
 - › **Peer-to-Peer Messaging** – This function of the application provides options for two systems to interact in the form of messages.
 - › **Messaging Batch** – This function processes information in message batch mode. This function is associated with the option of use of emails, where email communications are utilized for informing a group of end users or relevant stakeholders, upon completion of specific system processes such as availability of the data in the application.
 - › **API/Web-Services** – This function of the solution provides options for integrating with REST/SOAP based functions of data transfer, using the IS/IP.
 - › **Managed File Transfer/Integration** – Use of this function provides methods for file transfers between systems, both outbound and inbound. The EDW solution leverages the IS/IP Managed File Transfer module for this process.
- **AWS** – The AWS component in the data movement layer provides a list of AWS services that are leveraged for data movement in and out of the EDW solution. Listed below are the features deployed based on project needs and requirements:
 - › **AWS API Gateway** – The AWS API Gateway is the service that is leveraged to translate the request and generate the response.
 - › **Lambda, SQS/SNS** – Lambda, Simple Queue Services (SQS), and Simple Notification Services (SNS) provide serverless computing power required for resolution of request and generation of response. These services are also used for internal management of the AWS components of the solution, like interconnectivity between various Virtual Private Clouds (VPCs).
 - › **Compute, Storage, Archive, and Backup** – Some of the additional services that are required for the EDW implementation include compute power, logical servers called Elastic Compute Cloud (EC2), automated backup functions to provide the ability to restore servers in the event of a disaster, and archival of data and documents using Simple Storage Services(S3). EC2 is a virtual computer that is made available by AWS for installation or configuration of the software or other services. S3 is a storage service providing the ability to store objects using a web interface.

- › **Direct Connect and Network Failovers** – The EDW solution uses the Direct Connect service provided by AWS for connecting with external networks such as the IS/IP, FMMIS, or the Agency.
- › **Audit Logging and Monitoring** – The EDW solution uses the native AWS features CloudWatch and CloudTrail in addition to using Splunk for system monitoring and generation of system logs. The EDW solution also uses native Aurora and Redshift capabilities to generate database logs. The applicable indexers, alerts or reports for logs from the EDW solution will be shipped to the IS/IP monitoring solution.
- › **Role Based Access** – The EDW solution configures personas and role-based access for individual system users, including the system accounts used by EDW administrators.
- › **LDAP, Encryption and Certificate Management** – Additional services, such as security certificates, configuration of active directory for role mapping, and encryption services for the storage objects are used from the AWS services catalog. The EDW solution will integrate IS/IP vendor's ForgeRock solution for configuration of Single Sign-On functionality.

3.2.3 DATA STORAGE AND PROCESSING

Once the data lands in the EDW network, various tools are used for processing the data to prepare it for use by the end users. This also includes different storage mechanisms for easy retrieval and access of information. In addition, this group includes software or services that are leveraged for enriching the source data information. Listed below are the components of the data storage processing layer:

- **Operational Data Store** – The operational data store is the first layer of data storage, storing information in its native format as provided by the source systems. The ODS layer will not employ any data modification, in order to maintain the integrity of the data as reported by the source systems. This also helps in validation processes to identify any potential issue with the data movement components. The ODS is housed in the AWS Aurora database and may include multiple schemas or logical segregation to store information per business needs. The ODS includes two structures:
 - › **ODS Replica** – This database structure stores the data as it is received from the source systems. This structure is used by the AWS DMS function to copy data from the FMMIS OLTP.
 - › **ODS Evolution** – This database structure is designed to align with the Agency's vision for the enterprise module integration plan.
- **Content Management** – The content management layer provides storage for objects as determined during requirement validation sessions. This may include images, documents, and other artifacts as required. Content management is comprised of five main objects:
 - › **File Indexer** – The file indexer is the solution connecting with file store and the content database to provide easy retrieval of the documents.

- › **File Store** – The file store component of the solution is used for actual storage of the objects identified during requirements validation and design sessions.
 - › **Content** – The content component stores documents and relevant Binary Large Objects in the database.
 - › **Redaction Engine** – This Consent management function of the solution uses Teradata Teradactor for redaction of information from the content that is being stored, as defined during design and requirement validation sessions.
 - › **DocuEdge** – DocuEdge is the code base that is part of the EDW solution used for the content management activities.
- **Metadata** – The metadata management component of the solution provides solution features that are required for the management of data about data in the solution. This includes data lineage and source to target mappings for the ETL transformations.
 - **Reporting Data Store** – The reporting data store is a relational database hosted on Amazon Aurora, used for generation of standard or canned reports as identified during requirement validation sessions.
 - **Analytics Data Store** – The analytics data store is used by the end users for self-service features based on a data set standardized for self-reporting. This store is hosted on Amazon Redshift.
 - **Data Marts/Specialized Data Store** – The specialized data marts are a logical group of tables which serve a special purpose. The set of tables in individual data marts support business needs for the specialized areas such as episodes, financial reporting, health events, Program Integrity/Surveillance and Utilization Review Subsystem (SURS), T-MSIS, Management and Reporting System (MARS), and HEDIS. Population of data in these marts is reliant on availability of information from the source system and respective data processing engines from the Agency such as HEDIS measures.

3.2.4 INFORMATION DELIVERY

This part of the solution contains the tools that are used for making the data and information available for the end users. This includes tools such as Cognos, Semantic Open Source Software (SEMOSS), and Python scripting, that are used for producing consumable forms of data. This portion of the solution is responsible for generating standard reports with predefined structures, frameworks for the end users to create ad hoc reports, and methods to share the reports and information with allowed user groups. The list below provides details on individual components of this layer of the solution:

- **Reporting (Standard/Ad hoc)** – This method of information delivery includes creation of pre-configured reports in Cognos Analytics. The prompts, the structure of the report, and business rules for generation of the report are agreed upon during the design phase. In addition, using reporting packages created in Cognos Analytics with Framework Manager, users with required privileges can create their own reports.
- **Analytics (Statistical/Visual)** – The SEMOSS component of the solution will be used by the end users and EDW team for data analysis based on algebraic methods as well

as for creation of dashboards, maps, or other forms of visual representation of data for interactive use by the end user group.

- **Request and Response Inquiries** – Another form of information delivery is delivery of data on business demand. In this method, data is delivered to the end users through a secured data delivery method or a summary view of data can be shared through agreed upon methods, to support ad hoc data needs for business purposes.
- **Predictive Analytics** – The EDW solution will leverage pre-configured functions available in Cognos Analytics, Python, and SEMOSS for providing advanced data analysis methods to create analytical models for prediction as per the outcomes of the requirements validation and design sessions.
- **Operational** - This feature of the EDW solution uses built-in features of Cognos Analytics to provide end users with notifications based on criteria identified in a particular report or data element. These features can also be leveraged to push reports or outcomes to the end users based on a defined schedule in the form of an email and a file push to a defined location.

3.2.5 INFORMATION CONSUMERS

This portion of the solution mainly consists of the front-end portal leveraged by the users to access the solution. Though the portal is the single entry point for the solution and all the system users will use the same portal for access, what individual users see post-login, is dependent on the persona or the user role they have been assigned. This portion of the solution also includes the authentication component that integrates with the IS/IP vendor solution for Single Sign-On authentication. Listed below are components of the information consumer layer:

- **Access Channels** – Access channels of the solution comprise various front-end modules that are used by business users for data analysis and reporting. This includes solution functions such as Cognos Analytics, SEMOSS, and the Information Governance Catalog for metadata reporting and data lineage information, all through a unified solution portal for the end users.
- **FX Users** – This function of the solution associates the end users with a persona, identifies the solution features, and the representation of the solution portal that individuals access. Details of personas and these features have been discussed in Section 5 of this deliverable.

3.3 INFRASTRUCTURE VIEW

The Infrastructure view of the solution provides the underlying hardware components leveraged to support the technical and business views. Included within the Infrastructure view is a representation of constructs used by the solution such as clustering. The figure below provides an overall infrastructure view, as it is planned for the EDW solution:

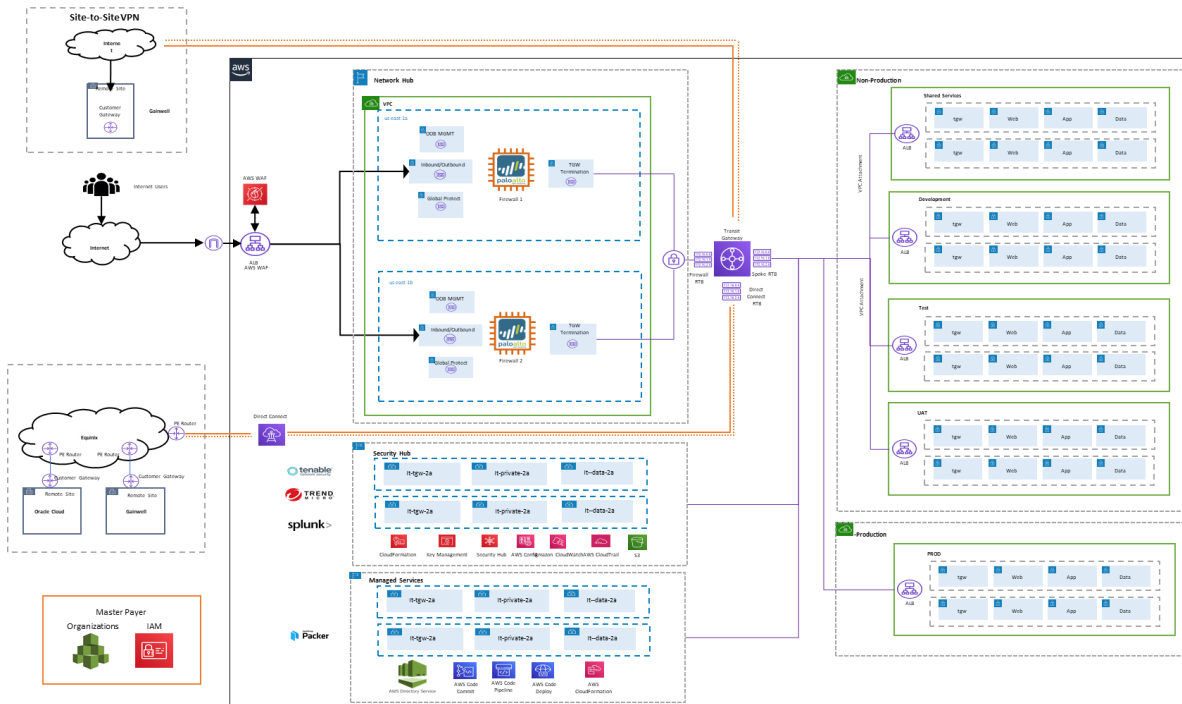

Exhibit 3-3: Infrastructure View

The infrastructure view of the solution consists of following components:

Virtual Private Cloud – Setup of virtual private clouds includes configuration of individual components that are required for each environment. This includes EC2 instances (virtual machines), storage devices such S3 buckets or services such as AWS Lambda, directly procured through AWS. Development, System Integration Test, and User Acceptance Test environments share the same VPC and Production is deployed in a standalone VPC.

Network Hub – Solution components that are required for managing the networking, both internal and external for the external solution, are maintained in this group. This includes the firewall, VPN, direct connect, and application load balancers.

Security Hub – This portion of the solution consists of the dedicated software and services that have been deployed for enforcing the approved security configuration for the solution. Components include Tenable, Trend Micro, Splunk, AWS CloudWatch, and AWS CloudTrail. The Security hub also integrates Palo Alto for management of the connectivity to the network. For additional security measures, signed certificates are generated using the AWS certificate manager.

Data stored in the EDW cloud solution is encrypted for security, both at rest and in transit. For the data at rest security, solution layers are encrypted with use of industry standard AES-256. Data rest is secured both at the EC2 instance boot and the Elastic Block Store (EBS) volume attached to the EC2 instance. These encryptions are applicable to any data transfer between the instances as well as between EBS and EC2 volumes. Any data transit out of the EBS

volume is protected using Secure Socket Layer (SSL) or Transport Secure Layer (TLS). Additional functions to apply client-side encryption are also available if a business need arises.

Management Hub – The Management hub is the portion of the AWS architecture used for administration of the applicable cloud components like VPC, instances, and services that are being used for the deployment of the EDW solution. Access to this portion of the cloud infrastructure is restricted to the system administrators only.

Disaster Recovery and Failover Approach – The EDW solution uses an active-passive approach for configuration of disaster recovery and failover solutions. An active backup approach is applied for the EDW AWS solution infrastructure and these backups are leveraged in the case of a disaster. Details of disaster recovery approach will be drafted in the deliverable PD-13: Contingency Plan (for Disaster Recovery and Business Continuity).

The following exhibit represents the icons used in the infrastructure view:













Network item	Description
	AWS Region: A geographical area divided into Availability Zones. Each region contains at least two Availability Zones.
	Amazon Virtual Private Cloud (Amazon VPC): A service that lets you launch AWS resources in a logically isolated virtual network that you define.
	AWS WAF: A web application firewall that helps protect your web applications or APIs against common web exploits that may affect availability, compromise security, or consume excessive resources.
	Amazon API Gateway: An AWS service for creating, publishing, maintaining, monitoring, and securing REST, HTTP, and WebSocket APIs at any scale.
	AWS Lambda: A compute service that lets you run code without provisioning or managing servers.
	AWS Transit Gateway: Connects VPCs and on-premises networks through a central hub.
	Private Subnet: Defined as a subnet that does not have a Route Table entry that directs traffic to an Internet Gateway.
	AWS Internet Gateway: A horizontally scaled, redundant, and highly available VPC component that allows communication between your VPC and the internet.
	Virtual Private Gateway: A logical, fully redundant distributed edge routing function that sits at the edge of your VPC.
	Application Load Balancer: Provides enhanced container support by load balancing across multiple ports on a single Amazon EC2 instance.
	AWS Elastic Network Interface: A virtual interface that can be attached to an instance in a Virtual Private Cloud (VPC).
	Route Table: A set of rules, called routes, that are used to determine where network traffic from your subnet or gateway is directed.

Exhibit 3-4: Icons Used in the Infrastructure and Network View

3.4 NETWORK VIEW

The Network view of the solution provides a high-level of view of interaction points of the solution, with external systems.

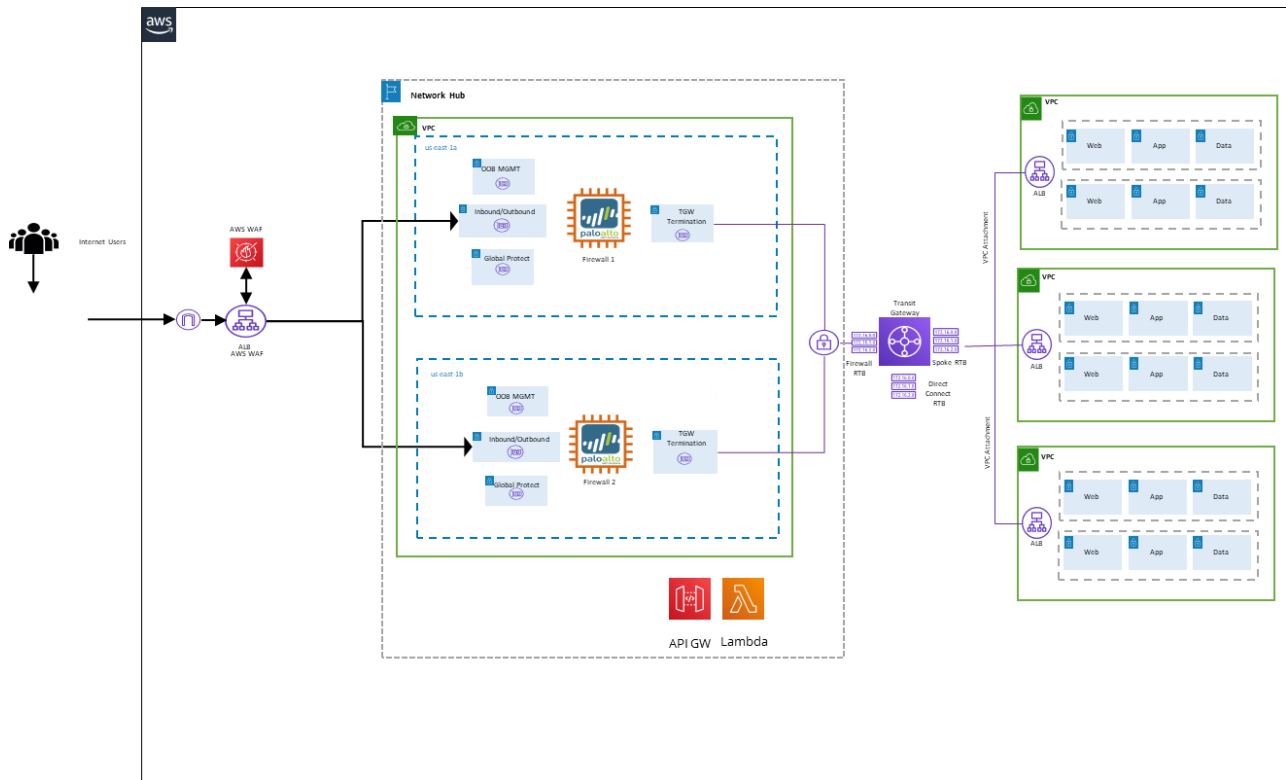

Exhibit 3-5: Network View

The list below provides the network considerations of the architecture:

- The network configuration leverages the Palo Alto firewalls to be the hub for all inbound, outbound, and inter-VPC traffic.
- Internet traffic is supported via the AWS internet gateway attached to the network VPC and load balanced through the attached Application Load Balancer (ALB).
- Transit Gateway and VPN are leveraged for inter-VPC connectivity.
- The AWS internet gateway is leveraged for the IP Network address translation and rerouting of required traffic.
- The AWS Lambda is used in conjunction with the AWS internet gateway to provide a network failover architecture.

3.4.1 INBOUND

The diagram below provides a flow of inbound traffic for the solution:

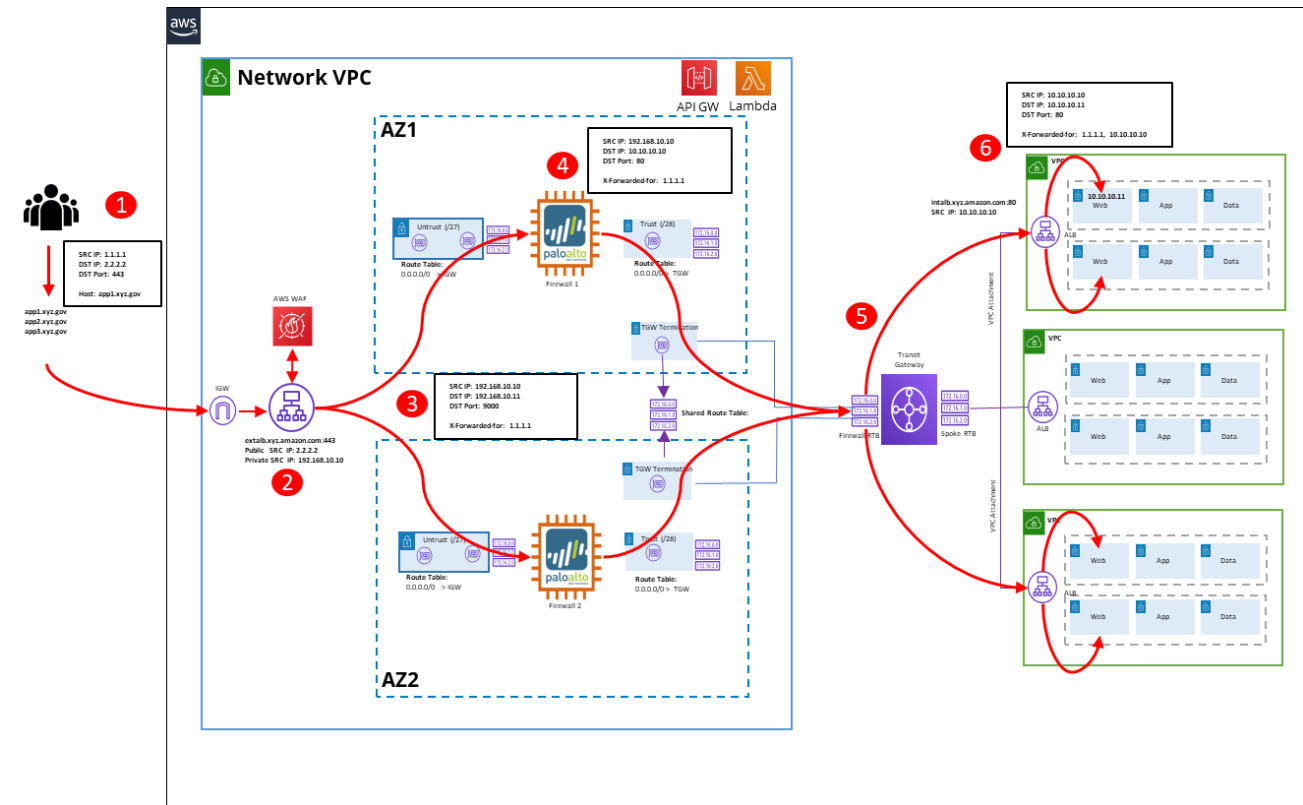

Exhibit 3-6: Inbound Traffic

Following are the flow details and the design principal for the inbound traffic to the EDW environment:

- Internet client accesses the link <https://app1.xyz.gov> (domain name to be finalized with configuration of environment) which resolves to the AWS external ALB `extalb.xyz.amazon.com`.
- The External ALB receives an encrypted HTTP request on its listening port 443 and terminates the SSL/TLS session. After SSL/TLS termination, the AWS Web Application Firewall (WAF) performs inspection using the AWS Managed ACL rules for WAF.
- The External ALB performs host based routing and modifies the destination port of the packet from 443 to 9000 based off of the host attribute defined in the HTTP header (The destination port is replaced to allow Palo Alto to correctly identify which NAT policy applies to the HTTP request so it can be routed to the appropriate internal ALB). Additionally, the External ALB replaces the original source IP in the L3 header of the packet with its own private IP. However, the external ALB will append the original source IP in the X-Forwarded-For attribute of the L7 HTTP header and replaces the original L3 header's destination IP to the inbound interface of the Palo Alto.
- The Palo Alto receives the HTTP request packets from the external ALB with the modified destination port (9000), source IP (private external ALB IP), and destination IP (Palo Alto's inbound interface). As each application is identified by a unique

destination port, the Palo Alto matches this destination port to a configured destination NAT policy. This NAT policy allows the Palo Alto to route the HTTP request to the appropriate internal ALB by modifying the destination IP to the appropriate internal ALB private IP and additionally changing the destination port to 80 (which the internal ALB listener is configured on). Once the NAT is performed, the Palo Alto routes the request through an IPsec tunnel to the Transit Gateway.

- Transit Gateway receives the HTTP request packets from the network VPC attachment and routes the packets to the internal ALB through the relevant Spoke VPC attachment that is associated with the Spoke VPC in which the internal ALB resides.
- The internal ALB receives HTTP packets. After receiving the packets, the internal ALB replaces the L3 source IP of the packet with its private IP. Additionally, it appends the original external ALB source IP of the packet to the X-Forwarded-For field of the L7 HTTP Header before routing the packets to the application server.

3.4.2 OUTBOUND

The figure below provides a view of the outbound traffic from the EDW AWS solution to external systems or users:

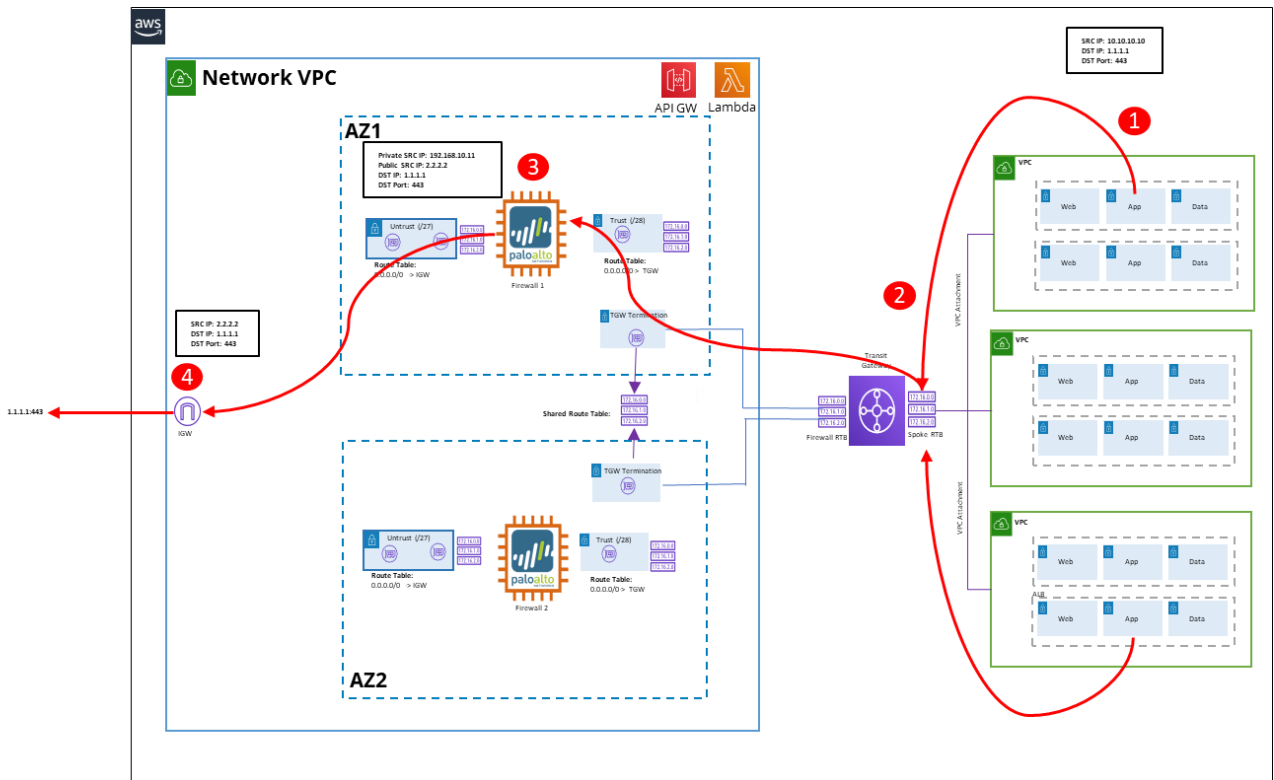

Exhibit 3-7: Outbound Traffic

Below are the flow details and the design principals for the outbound traffic to the EDW environment:

- The Application Server tries to perform an update through the internet. As this server address is not located in the server’s subnet/VPC, the server will route this traffic to its default gateway which is the VPC router. Once the VPC router receives the packets, it will route the traffic through its VPC attachment to the Transit Gateway.
- The Transit Gateway receives the packets through the VPC attachment associated to the TGW Spoke route table. As the Spoke route table has a default route to the internet via Firewall 1, the transit gateway will route the packets to the Firewall 1 trust interface.
- Palo Alto receives the packets and performs a NAT overload modifying the original source IP to its outbound interface private IP. The Palo Alto then routes the packets to the VPC router and then from the VPC router to the IGW.
- IGW performs NAT translation on the private source IP to its associated Elastic IP before sending the update out to the internet.

3.4.3 EXTERNAL CONNECTIVITY

In order to process data or respond to the user access requests, the EDW solution will be interacting with the other FX modules or the Legacy MMIS system. These methods of interconnectivity of the systems are dependent on the environment in use and the corresponding external system’s capacities.

Site-to-Site VPN

The option of Site-to-Site VPN will be used as a backup connectivity method, between FMMIS and EDW, in case there are issues with Direct Connect access. With this option, a connection is established between the Source system and the EDW solution, using a VPN tunnel. The development environment plans to use the Site-to-Site VPN to connect with the FMMIS development environment.

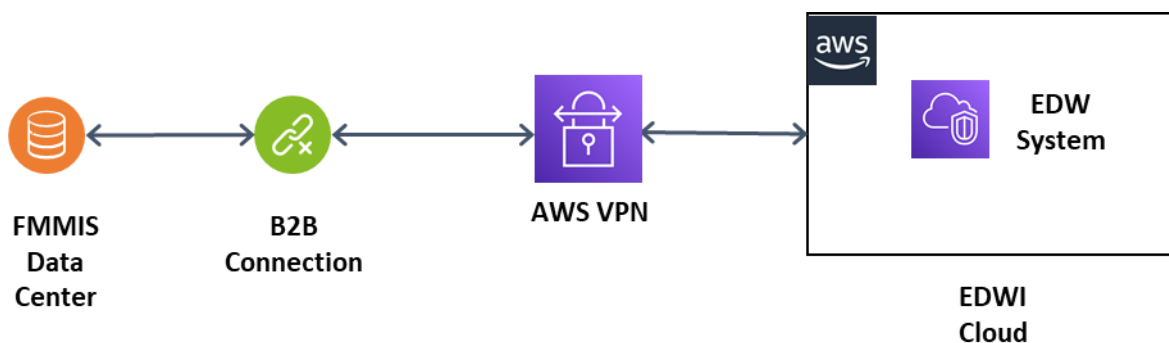

Exhibit 3-8: Site-to-Site VPN

Equinix and AWS Direct Connect

The Agency has decided to use Equinix as an integration platform to support the FX program networking needs. The EDW solution will use AWS Direct Connect to interact with other

systems in the module. Equinix will be the hub through which individual systems will communicate with other modules. The diagram below provides a depiction of these connections:

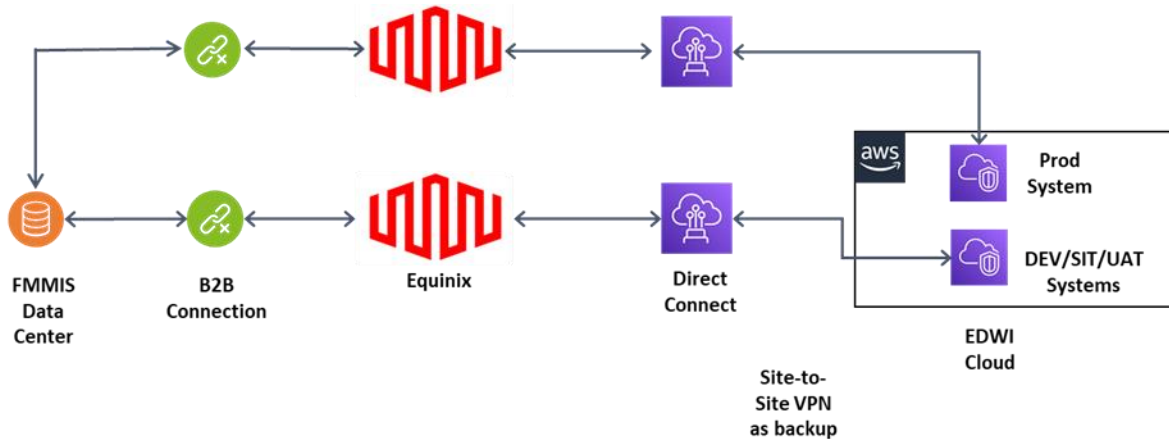

Exhibit 3-9: Equinix and Modules

The following are the considerations of this design approach:

- The planned Equinix solution hub supports a 5 Gbps pipeline for data transfer. Equinix hub will support the communication channel of 1 Gbps for EDW Direct Connect services.
- AWS Direct connect will provide connections with Equinix, which in turn will route the traffic between FMMIS and the EDW solution.
- Future integration with other modules, for example IS/IP, will use same communication methods.

Module Network Integration

With integration of future modules, the EDW solution will be required to connect with individual modules. This will provide connectivity methods for new modules and also define their data needs. One such example is the IS/IP module. The EDW solution will integrate with the IS/IP solution using components such as ForgeRock, Enterprise Service Bus, and Managed File Transfer. IS/IP and the EDW solution will communicate through use of Equinix. Users authenticating with the EDW solution will leverage the Single Sign-On features provided by the IS/IP solution through ForgeRock. Users will be authenticated against ForgeRock and the corresponding assertion in the form of a SAML/Open ID tokens. This token will be provided to the EDW solution to grant access, post-authorization, for individuals based on their roles. The figure below provides a high-level view of the IS/IP Identity and Access Management (IAM) solution and the EDW solution integration:

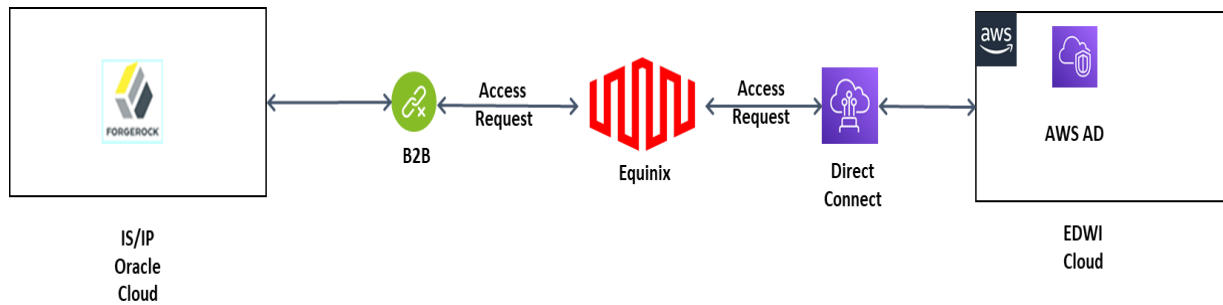

Exhibit 3-10: IS/IP IAM and EDW Integration

Section 4 SOLUTION COMPONENTS

The solution components section of this document identifies individual objects configured and managed to provide specific services for the EDW solution.

4.1 DATA INTEGRATION

As EDW solutions are designed to be the single source of truth for the organizations, data integrations become a critical part of the solution as it provides the mechanisms to integrate data from disparate sources. The Source system will use different methods for communicating with the EDW solution and will provide input in various formats. The subsections below provide an overview of the components that are leveraged to ingest information from the sources identified for the EDW project.

4.1.1 DATA REPLICATION

Data replication is one of the most critical requirements of the EDWI project. Data replication services will be used for near real-time migration of source system data to the ODS Replication Layer of the solution. The AWS Data Migrations Services are leveraged for the source system replication as well as for the feedback process to the source system, like bi-directional replication. Listed below are the key steps for the source system data replication from the FMMIS OLTP database:

- Identify the list of tables that will be replicated to the ODS replication layer.
- Identify the cut-off time period for the data replication.
- Setup data transfer rules in the AWS DMS.
- Initiate the data transfer.
- Generate data transfer logs using the Audit, Balance, and Control module of the EDW solution.

For modules that may be integrated with the EDW ODS in the future, use of DMS or web-services for module integration will be defined during the design process for module integration.

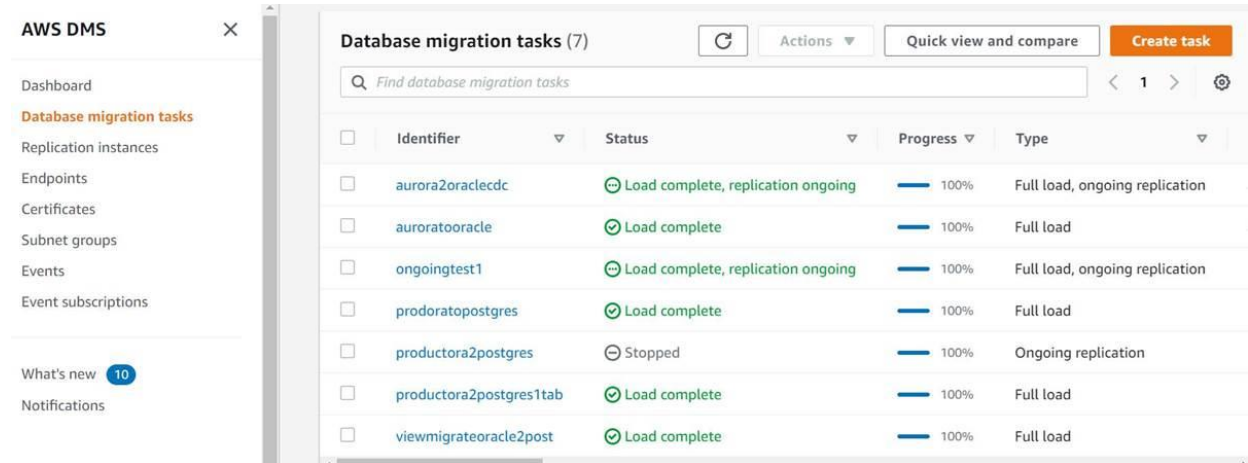

Exhibit 4-1: AWS Data Migration Services

4.1.2 ON-GOING DATA TRANSFER

AWS DMS will be leveraged for the OLTP data for the identified set of tables. This transfer will be near real-time. AWS DMS will use the log miner services configured on the FMMIS transaction database to identify the changes for data and will replicate the information to the ODS Replication Layer. The figure below provides an overview of the use of the DMS solution for near real-time data transfer from FMMIS OLTP to ODS Replica layer. ODS Replica Layer acts as the source for population of the ODS Evolution structures.

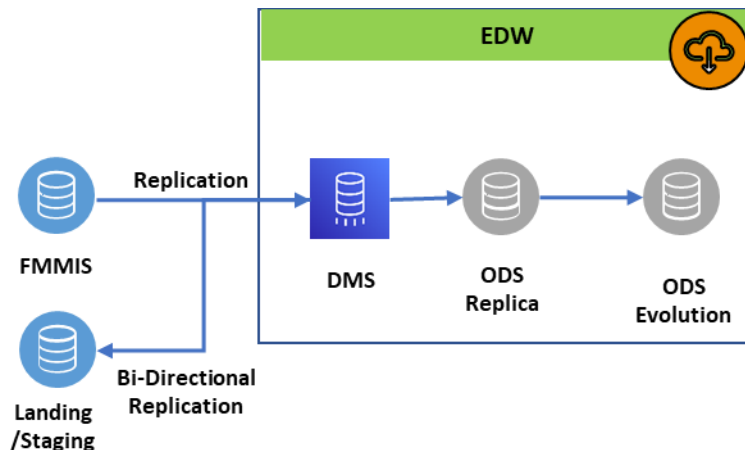

Exhibit 4-2: On-Going data Transfer

The figure below provides a representative IBM InfoSphere Data stage job, showing the ETL function of the solution:

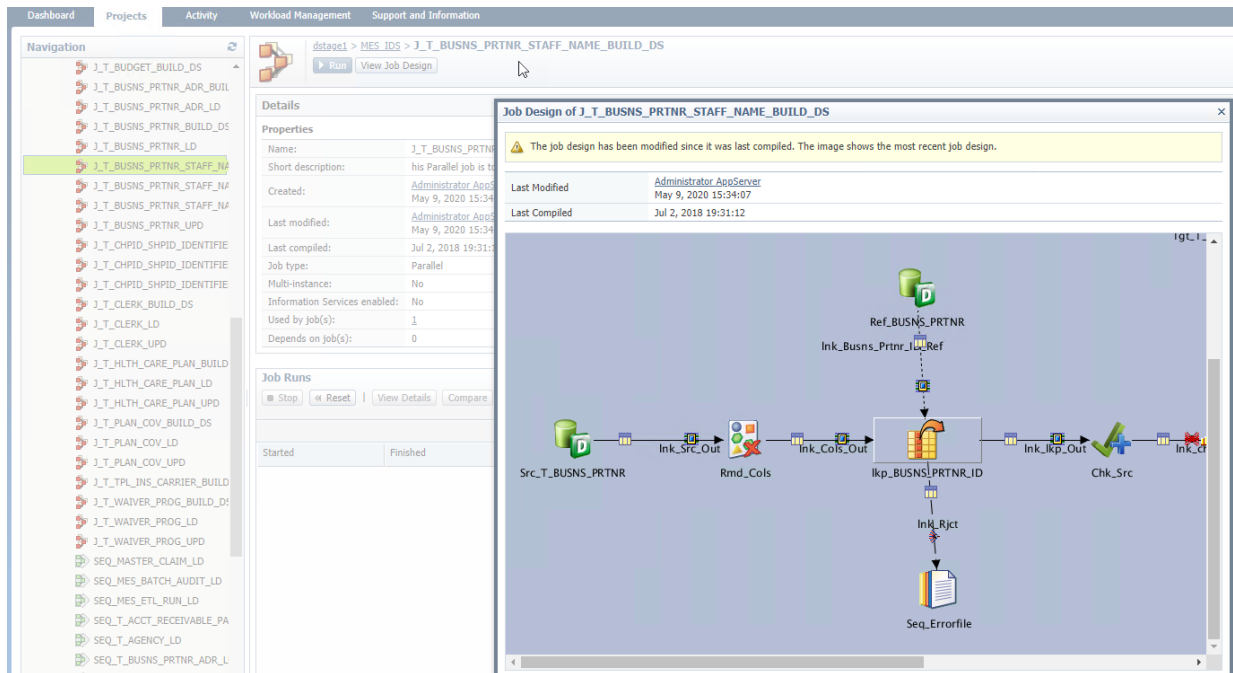

Exhibit 4-3: Representative Data Transformation Jobs

4.1.3 WEB-SERVICES

The EDW solution will leverage the IS/IP provided ESB and protocols for data services, in order to interact with external vendors and modules where web-services and/or API calls will be the agreed upon method of communication. The EDW solution will parse the request as received from the vendors for data, push the request to the ODS, and will load the information into the respective tables. Similarly, for data requests, the EDW solution will receive the incoming request through the IS/IP ESB and will push the data back to the ESB for the response based on the information received in the request from the vendor module. Transformation or submission of data through these API calls supports the current and future interoperability objectives of the Agency by allowing transmission of data that can be managed by the Agency in their interchange model. In order to process web-service calls, the EDW will leverage the following components as per the individual requirement:

- **API Gateway** – Provides the ability to create, publish, manage, and monitor the APIs to be used for data communication.
- **IBM Tools** – IBM tools such as IBM InfoSphere and IBM Cognos have the ability to consume data requests through APIs.
- **Lambda** – AWS Lambda provides serverless compute power for configuration and execution of programs.
- **JAVA** – Custom JAVA programs may be required. The solution has the ability to provide those programs.

The approach to and complexities associated with implementing data services against the Operational Data Store depends upon whether an implementation is subject to enterprise



policies and whether data consistency is the responsibility of the service provider or consumer. In Enterprise settings, these issues are typically governed by organizational policy. For example, FHIR servers and their data persistence would need to fit within that policy, with data access following that policy, and services interacting with "policy enforcement points" to assure that appropriate permissions are in place.

With the Agency's interoperability project, the responsibility resides with the service (or server) and its use of SOA-friendly interface protocols, such as SOAP and potentially REST, to create the access channel for integration. The EDW solution can provide available data sets necessary to fulfill the interoperability and patient access requirements through SOAP/REST data services to support the Agency's interoperability project.

4.1.4 DATA GOVERNANCE

As the EDW solution will be housing information from various source systems, it is of utmost importance that data is accurate and end users can identify the source of the information, as well as use a common term for similar data entries from different source systems. This functionality will be achieved in the EDW solution through use of the IBM InfoSphere Information Governance Catalog, depicted in Exhibit 4-4 below. IGC is integrated with the portal for ease of access for the end-users. The key features of the IBM IGC include:

- **Data Dictionary** – A data dictionary of applicable data elements is maintained in the IGC, where end users can search the information in the form of a wild card search.
- **Data Lineage** – As data goes through multiple hops before it is consumed by the end users, it is important to provide the source details for those attributes so that end users can make informed decisions. The Data Lineage feature of the solution tracks individual data elements from the presentation layer of the solution to its source and also identifies any transformation that may have been applied to the element.
- **Report Catalog** – A report catalog helps end users search for specific reports and analyze the business rules that may have been applied for the production of that report.
- **Source to Target Mappings** – An extension of the data lineage function is the availability of the source to target mapping documents used by end users to understand the transformation applied before storing the information into a target table.

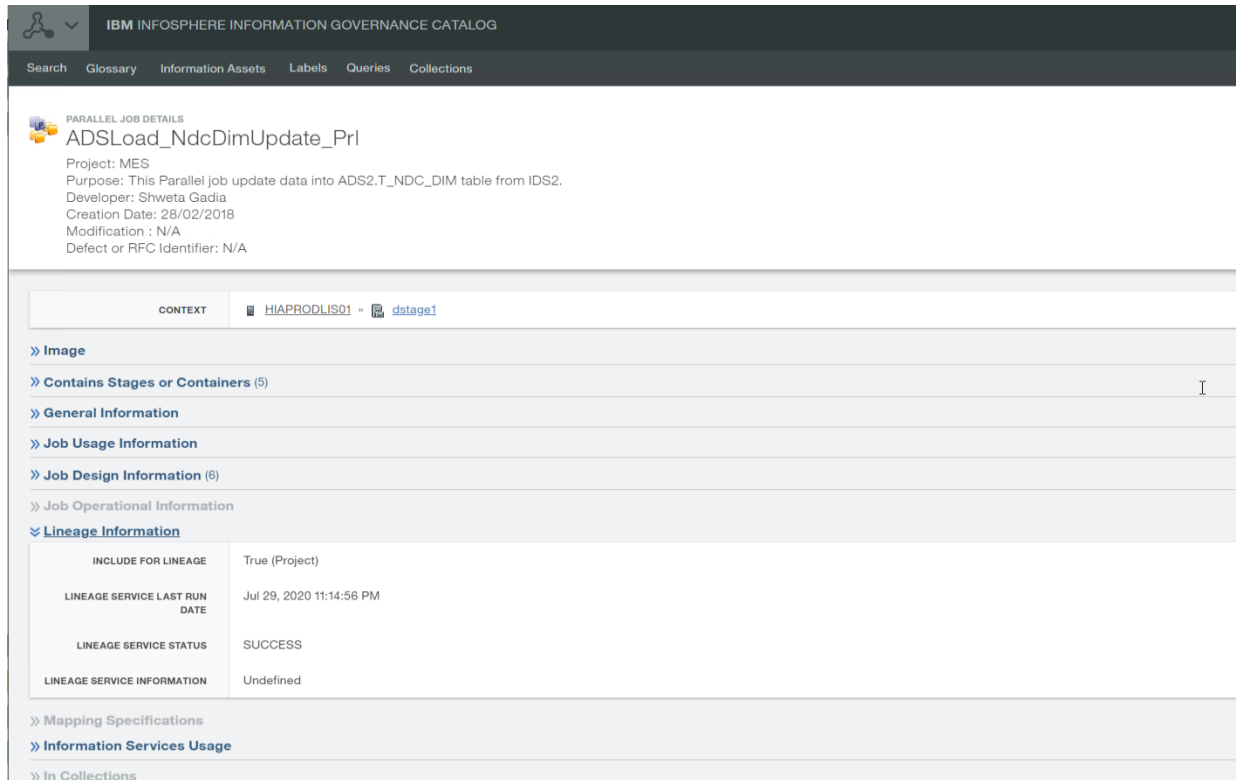

PARALLEL JOB DETAILS
ADSLoad_NdcDimUpdate_Prl
 Project: MES
 Purpose: This Parallel job update data into ADS2_T_NDC_DIM table from IDS2.
 Developer: Shweta Gadia
 Creation Date: 28/02/2018
 Modification : N/A
 Defect or RFC Identifier: N/A

CONTEXT: HIAPRODLIS01 - dstage1

- » Image
- » Contains Stages or Containers (5)
- » General Information
- » Job Usage Information
- » Job Design Information (6)
- » Job Operational Information
- » Lineage Information

INCLUDE FOR LINEAGE	True (Project)
LINEAGE SERVICE LAST RUN DATE	Jul 29, 2020 11:14:56 PM
LINEAGE SERVICE STATUS	SUCCESS
LINEAGE SERVICE INFORMATION	Undefined
- » Mapping Specifications
- » Information Services Usage
- » In Collections

Exhibit 4-4: Metadata Management

The exhibit above provides a representative view of the IGC, which shows some examples of the menu options available which are used for supporting the data governance processes. This includes ability to incorporate terms in Glossary, identification and tagging of information assets, labels used for various objects, and queries or collections for the end users based on their search operations. Information assets will include objects such as data lineage, pre-configured report details, as well as visual representation of various ETL jobs.

4.1.5 CONTENT MANAGEMENT

The Content Management component of the solution includes management and storage of files, images, and documents. The Content Management component will utilize the IS/IP Managed File Transfer (MFT) services for transfer of content from the source systems to the EDW solution. These connections will be managed through Equinix, as the EDW module and IS/IP module will connect individually to Equinix and Equinix will route the traffic accordingly.

4.2 DATABASE ARCHITECTURE OVERVIEW

Databases are the key component of the EDW solution. The EDW solution includes various databases and data marts to fulfill the requirements of the FX EDW Project. Listed below are the databases and their purpose for the EDW project and the end users:

- Operational Data Store** – The Operational Data Store is used as the single version of the truth for historical data available to the Agency and also acts as the single source of information for any future module integration. The ODS consists of two major components: the ODS Replica and the ODS Evolution. The ODS replica is an exact copy of the FMMIS OLTP structure, only replicating the tables deemed necessary for ODS usage. The ODS Evolution leverages the SEAS Logical Data Model and FMMIS OLTP model to create an efficient physical model for the Agency. The ODS is housed in Aurora Postgres.
- Reporting Data Store** – The Reporting Data Store is a relational data model created to perform standard reporting and canned reporting for the EDW solution. In addition, the RDS is also leveraged for feeding data to the Analytical Data Store and the specialized data marts. The RDS is housed in AWS Redshift database.
- Analytic Data Store** – The Analytical Data Store is a dimensional model used by the end users mainly for self-reporting or for execution of advance analytical functions such as Python algorithms for data analysis. ADS is housed using Amazon Redshift database.
- Specialized Data Marts** - The Specialized Data Marts are created for the purpose of producing and maintaining the needs of specific business functions. These include marts for Transformed Medicaid Statistical Information System (T-MSIS), financial reporting, episodes reporting, SURS/PI mart, health events, HEDIS and MARS reporting. These marts are hosted in Redshift and are a logical and/or physical grouping of business function related objects.
- Content Management Data Stores** – Content Management is used to store documents and other relevant objects as they relate to the EDW solution. In addition to the use of file storage and file indexing, information is retained in AWS Relational Database Services SQL for easy retrieval of the information.

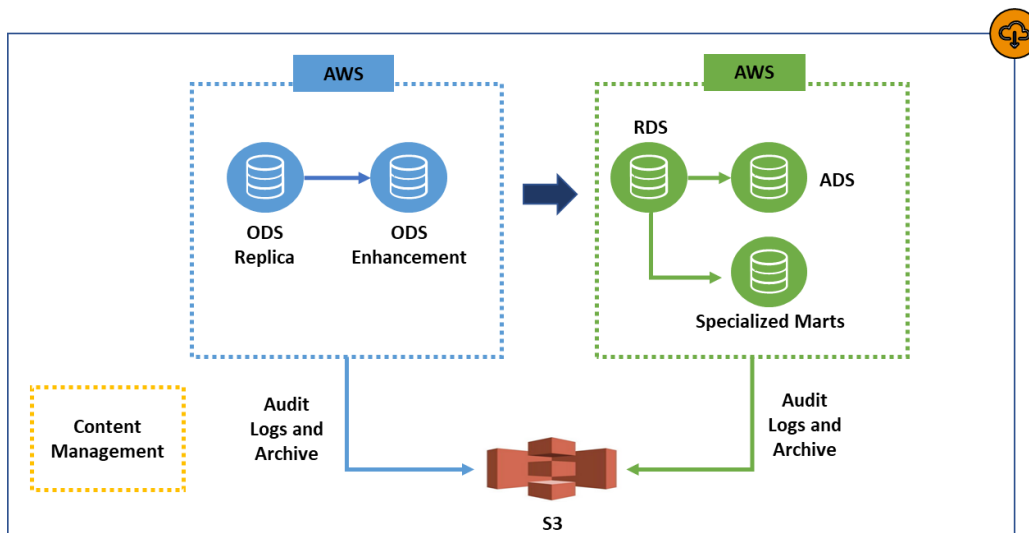

Exhibit 4-5: Database Architecture Overview

In addition to the use of relational databases that are required for information storage, and structured reporting and analysis, data is also retained in AWS Simple Storage Services (S3). Objects that are stored in S3 include audit logs and archived data. AWS S3 provides easy retrieval of the information and is a cost effective mechanism for storage of information, especially in cases where data is not necessarily structured.

4.3 ENVIRONMENT CONFIGURATION

The EDW solution contains five environments for the implementation and support of the FX EDWI project. These environments serve a different purpose and are aligned with the software development life-cycle of the project. Configuration of various environments follows different timelines based on the project schedule, e.g., ODS components of the solution will be configured early in the project and EADS components will follow. This method of configuration has been applied for the most efficient methodology of deployment and to provide a cost effective solution for the EDWI project.

Development Environment – The Development Environment is used by the EDW Vendor team for development and configuration of the EDW solution. It includes the components as highlighted in sections earlier in this document. Access to this environment is specific to the EDW Vendor team.

System Integration Test Environment – The System Integration Test (SIT) Environment is used by the EDW Vendor team for integration testing of the EDW solution. This environment is used by the System Integration Test Team and has restricted privileges for the EDW Vendor development and test teams.

The figure below provides a high-level pictorial depiction of inter-network connectivity for the development and SIT environment for the EDW:

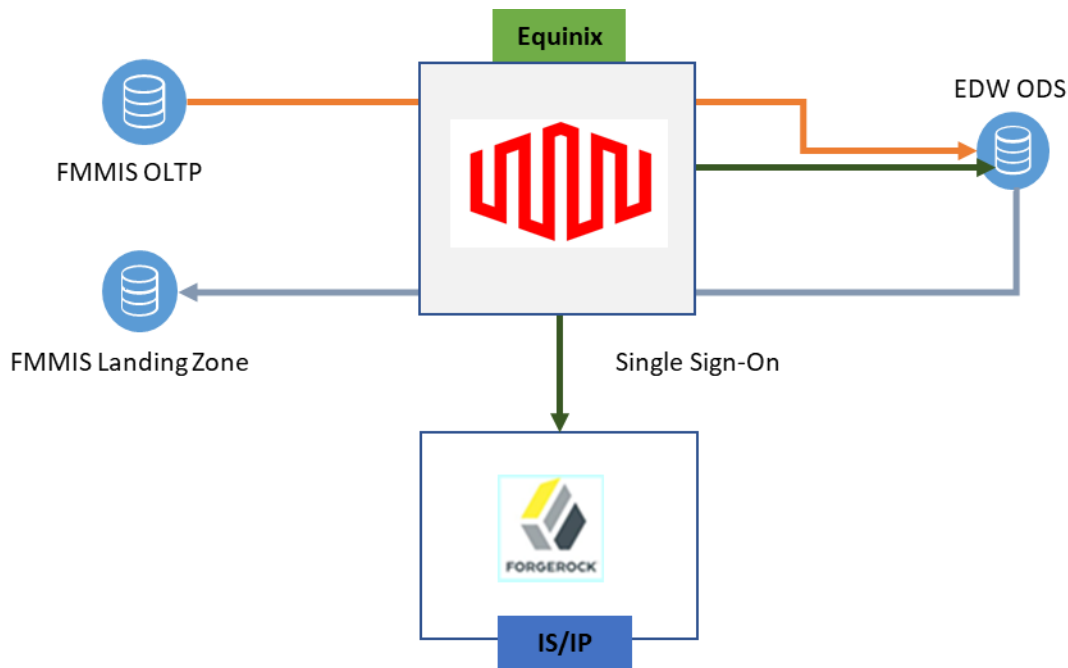

Exhibit 4-6: SIT Connectivity

User Acceptance Test Environment – The User Acceptance Test environment is used by the end users identified by the Agency for validation of the deployed functionality, as it relates to the business requirements associated with the function of the solution deployed. This environment follows the deployment protocols and security rules similar to the SIT environment, where changes outside of the deployment cycle are not allowed in the system. Code segments are deployed from the lower environments, based on the project schedule.

Production Environment – The Production Environment will have the final code deployment validated through the UAT process, including the required data and business functionality. This environment will have the finalized user roles configured and a defined method of system access deployed.

The figure below provides the connectivity approach for UAT and Production environment:

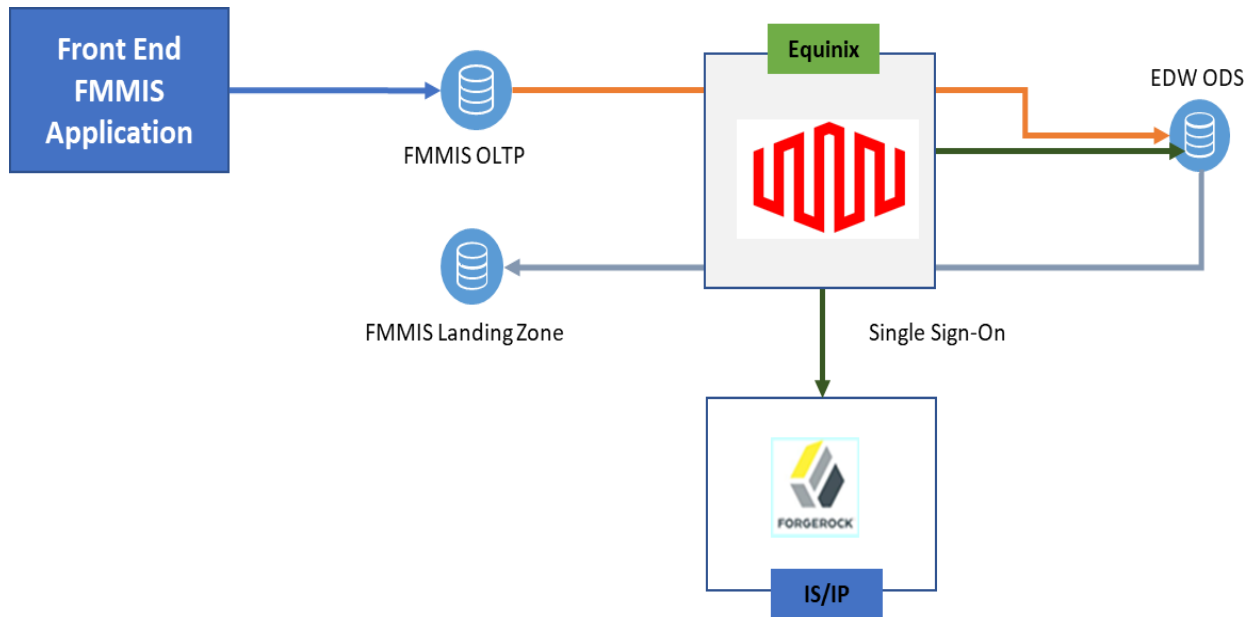

Exhibit 4-7: UAT and Production Connectivity

Disaster Recovery (DR) Environment – The EDW solution will maintain an active-passive DR environment. In the case of a disaster, the passive environment will be made available for the end users. Details of disaster recovery approach will be drafted in the deliverable PD-13: Contingency Plan (for Disaster Recovery and Business Continuity).

The figure below provides a high-level view of the environment deployment path.

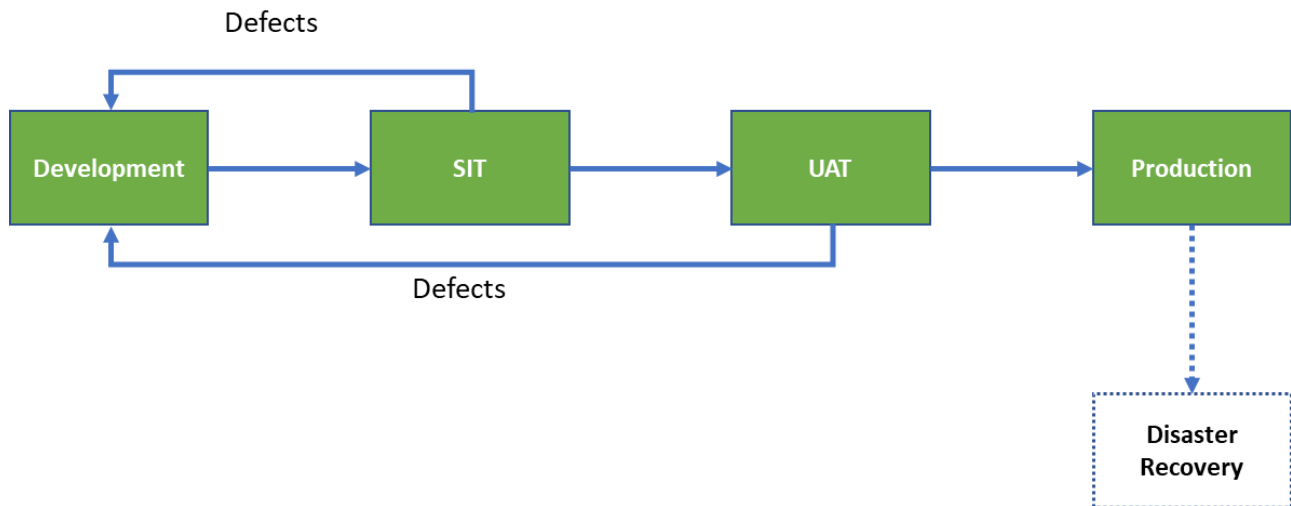

Exhibit 4-8: Deployment Path

Section 5 USER INTERACTION

The user experience is a key component of any data and analytics solution. It is critical not only to make the information available to the end users, but also to make information available to the end users in a form that requires minimal complexity to get to the required information. This is achieved in the EDW solution through use of a single portal for all the application access needs for the end user. In addition, the Persona Optimized Analytics and Reporting (POAR) approach is used to provide end users with a unique experience for their business needs as it relates to the EDW solution. User access for the end users of the solution will be controlled by the Single Sign-on with IS/IP ForgeRock.

5.1 INTERACTION METHODS AND FEATURES

End users will access the EDW solution through a unified portal, consisting of the following functions:

- Access to pre-defined standard reports.
- Ability to create ad hoc reports, depending on user role.
- Ability to use advanced analytical functions.
- Ability to access Metadata of the information available in the EDW.
- Access to EADS backend structures.
- Access to specialized marts.
- Integration with externalized tools, either hosted by the EDW Vendor or by the Agency, allowing connections to the database servers

The Solution Portal is designed using IBM Cognos Analytics and customized for individual personas. The figure below provides a representative view of the front end portal:

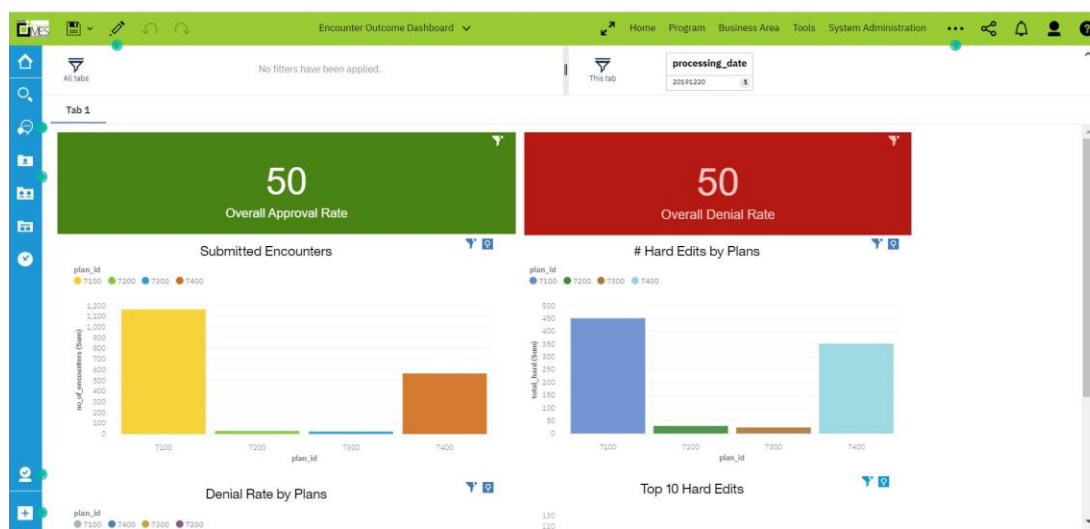
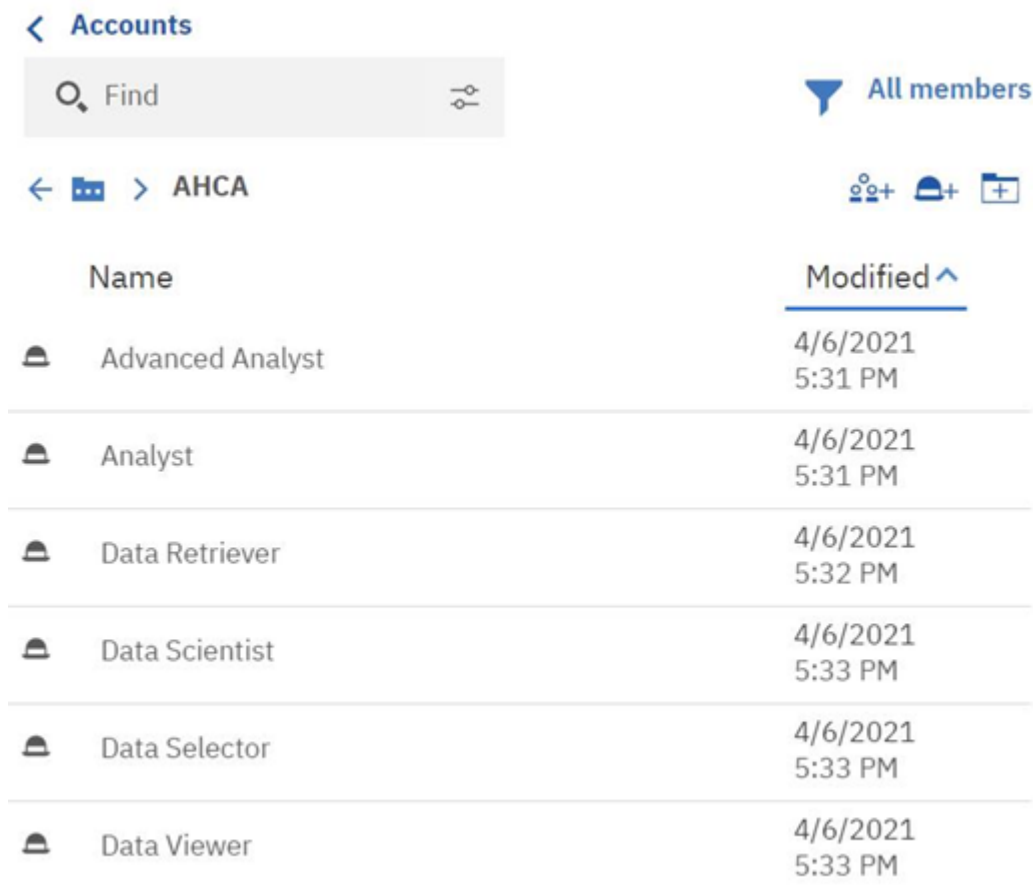

Exhibit 5-1: Representative View of Front-End Entry to the Portal

5.2 PERSONAS

The EDW solution incorporates user-specific personas based on the needs of the end user. The EDW solution uses Human-Centered Design (HCD) principles in the design process to leverage processes and techniques that put people first. The process to identify these personas starts with a review of existing user requirements and personas, and a mapping of the stakeholder ecosystem. This mapping leads to conversations with stakeholders and end users to identify their perspectives and business needs. These user personas are used to design user roles and develop reports and capabilities based upon the needs of the specific end users.

The figure below provides a representative view of the personas in the system:



Name	Modified
Advanced Analyst	4/6/2021 5:31 PM
Analyst	4/6/2021 5:31 PM
Data Retriever	4/6/2021 5:32 PM
Data Scientist	4/6/2021 5:33 PM
Data Selector	4/6/2021 5:33 PM
Data Viewer	4/6/2021 5:33 PM

Exhibit 5-2: Representative Personas



Section 6 MODULE INTEGRATION

The current DDI phases of the EDW project integrates with FMMIS as a source module. In order to meet the needs of the FX project goals and roadmap, the EDWI team will work with the Agency and other stakeholders to integrate with modules in the future, as those implementations are realized. Listed below are some important considerations for the integration of a new module to the EDW solution:

- 1. Data Integration Methods** – The first step is to identify the methods of integration. External modules can work in either batch mode or in near real-time mode. Based on the Agency's requirements, the EDW vendor will work with the configuration of batches or web-services for integrating data transport mechanisms with the modules.
- 2. Security** – One key aspect of integration with modules is the identification of network connectivity as well as the security mechanisms around it. One example is identifying if the module will integrate with the EDW using IS/IP or Equinix, or a direct connect with the EDW. In addition, the systematic process of interaction between two modules will be also dependent on the method of security rules configured in both the systems.
- 3. Data Conversion Approach** – Another key aspect of module integration is identification of the data needs of each module vendor, as well as their preferred mode of data transfer. This includes identification of the source systems, amount of data identification, and methods of bulk data transfer. The EDW solution is capable of allowing direct connection and sourcing of data from the ODS or extracts of data based on the Agency's subject area profile, from which the module vendor can load.
- 4. Data Deidentification** – Due to the sensitive nature of data housed in AHCA's Medicaid enterprise solutions, data security is critical. One security design pattern to follow is the rule of least privilege. This can be enforced by removing access to live data in the development and testing process. Another consideration for security of this data is the future integrated testing across module vendors and avoiding live data being permeated for this purpose. In order to reduce AHCA's risk exposure, data should be deidentified while still maintaining the integrity of the data to allow for development and testing purposes. The EDW solution is capable of addressing deidentification through tokenization, which is a process of using algorithms to replace and maintain the integrity of data while not exposing the original values. Tokenization uses a configuration parameter file with runnable routines against a defined data source and requires the management of a specific security key used in the setup of the tool.



APPENDIX

6.1 APPENDIX A

For a definition of terms and acronyms used throughout this document, refer to the [FX Projects Glossary](#) located in the FXPR (Florida Health Care Connections > Project Glossary).

6.2 APPENDIX B

The graphics used in this document have been consolidated in a separate attachment: FX-EDW-High-Level-Technical-Design-Attachment.

Exhibit 3-1

EDW-IMG-001.2

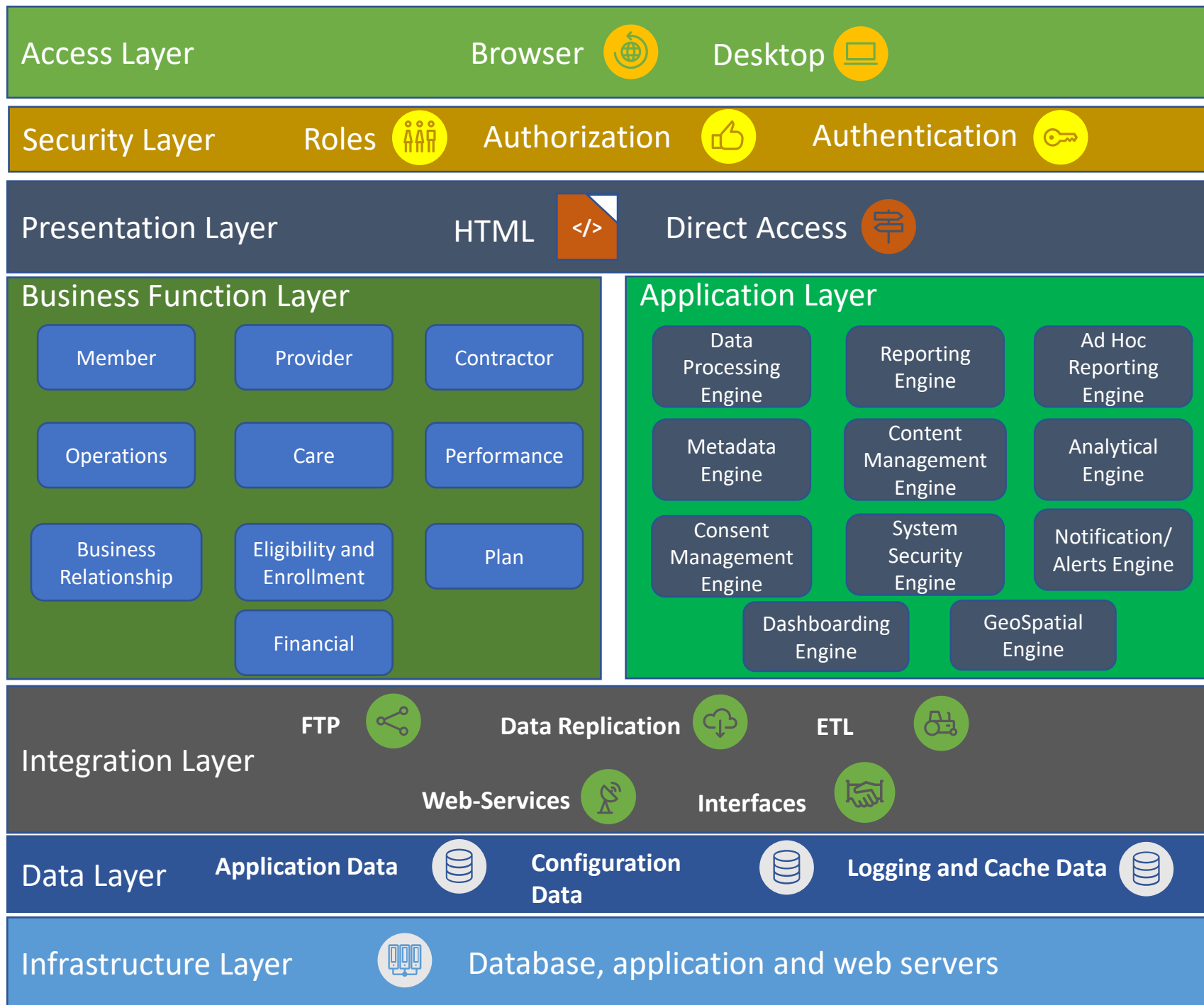

FL AHCA Enterprise Data Warehouse Architecture

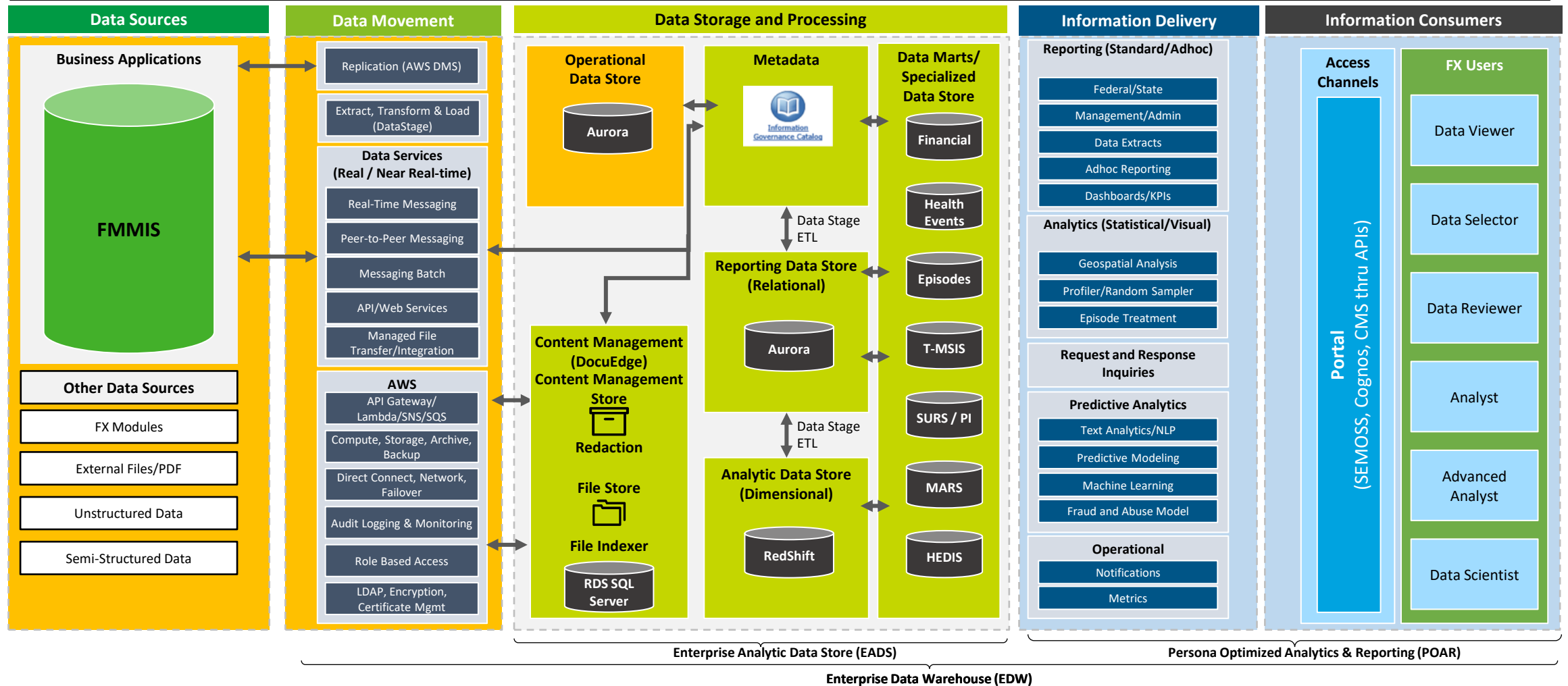

Exhibit 3-3

EDW-IMG-003.2

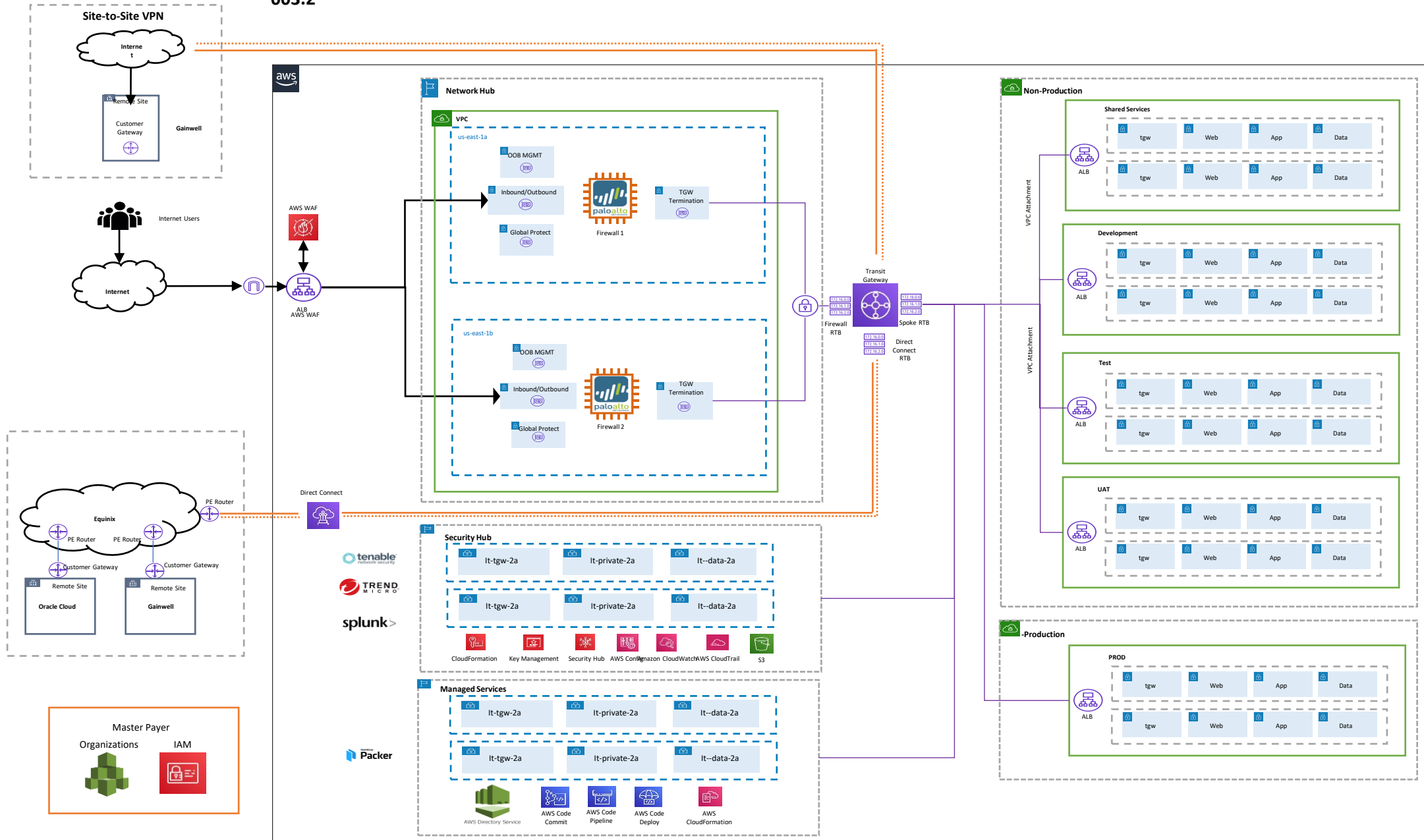

Exhibit 3-5

EDW-IMG-004.1

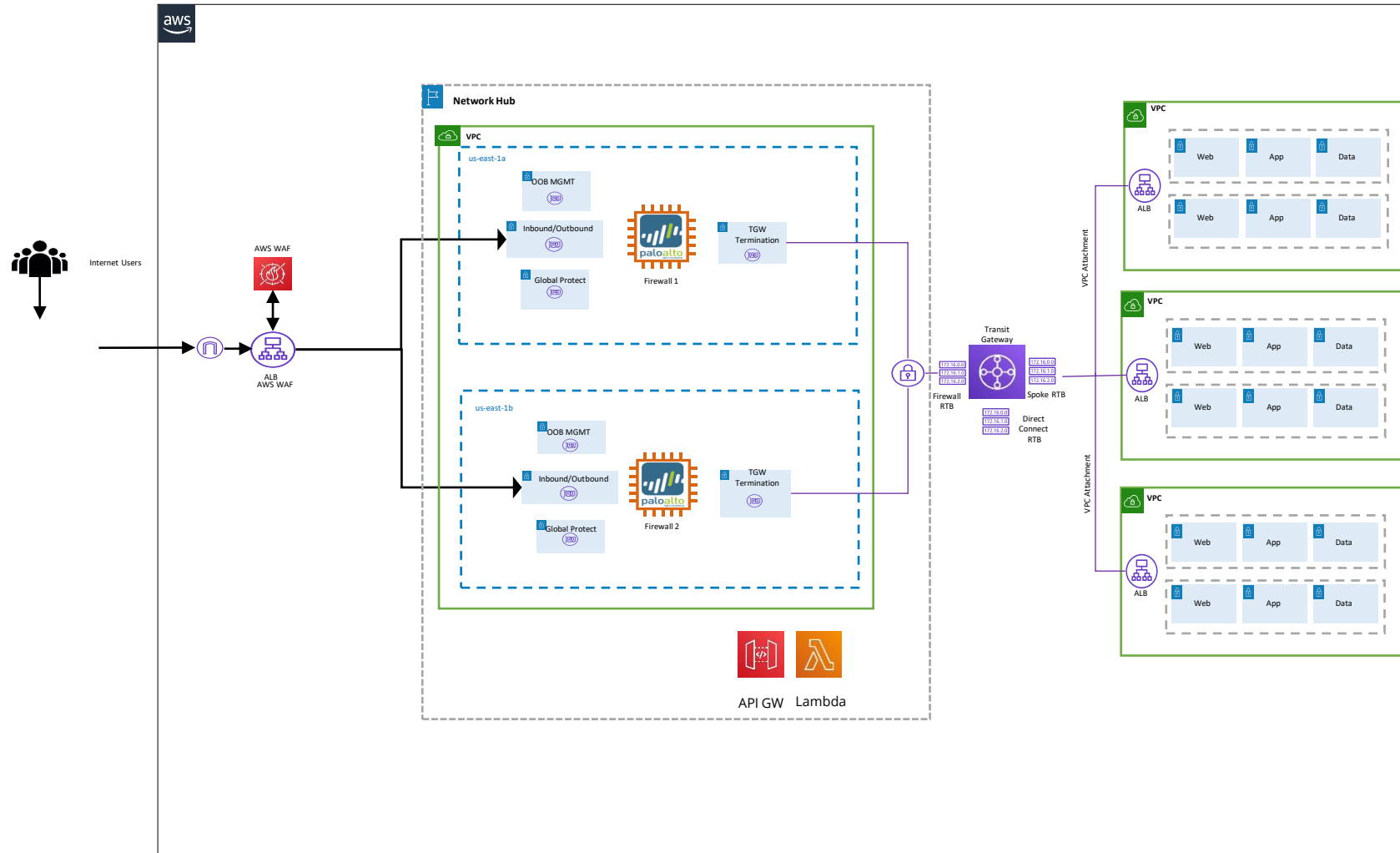

Exhibit 3-6

EDW-IMG-005.1

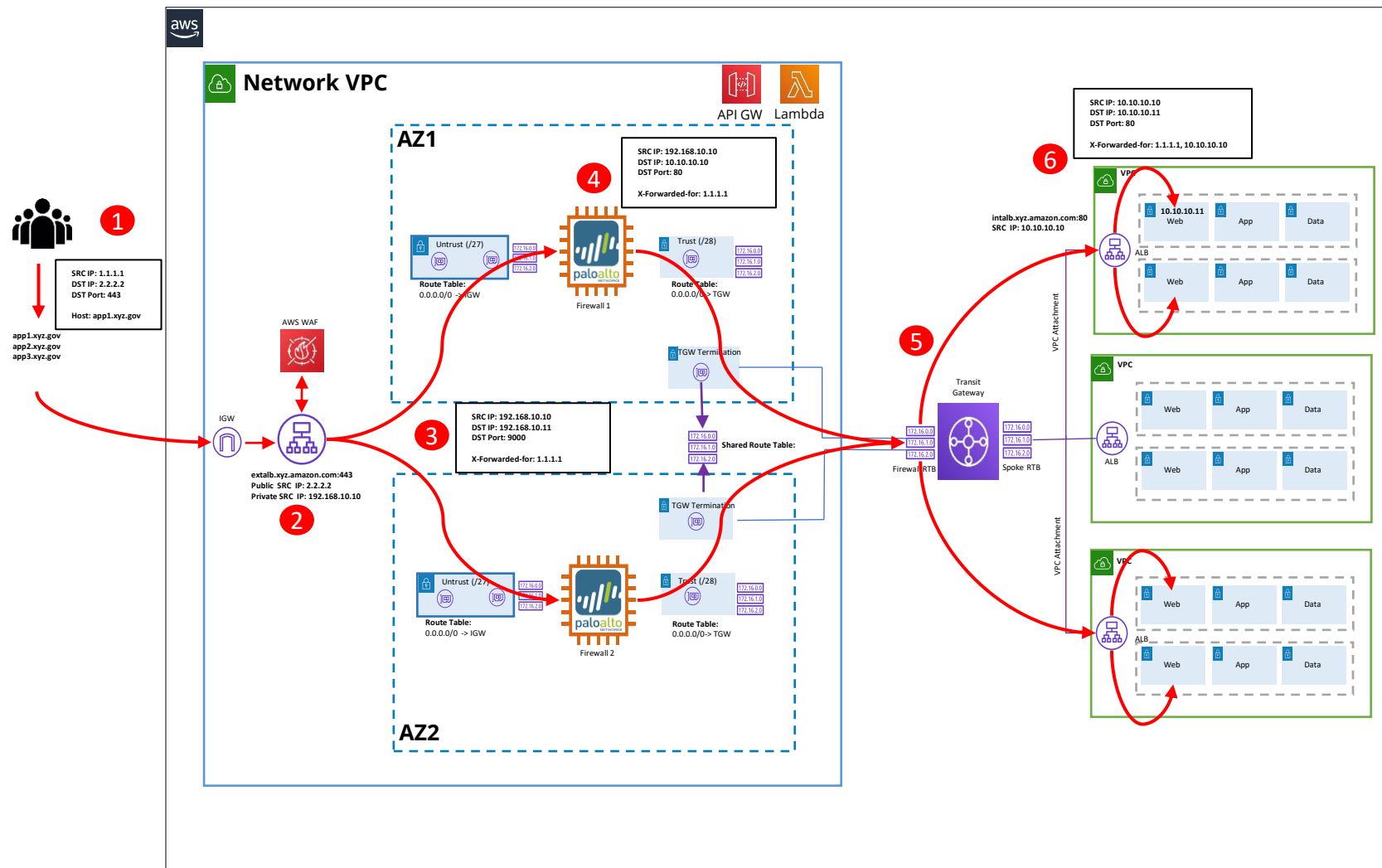

Exhibit 3-7

EDW-IMG-006.1

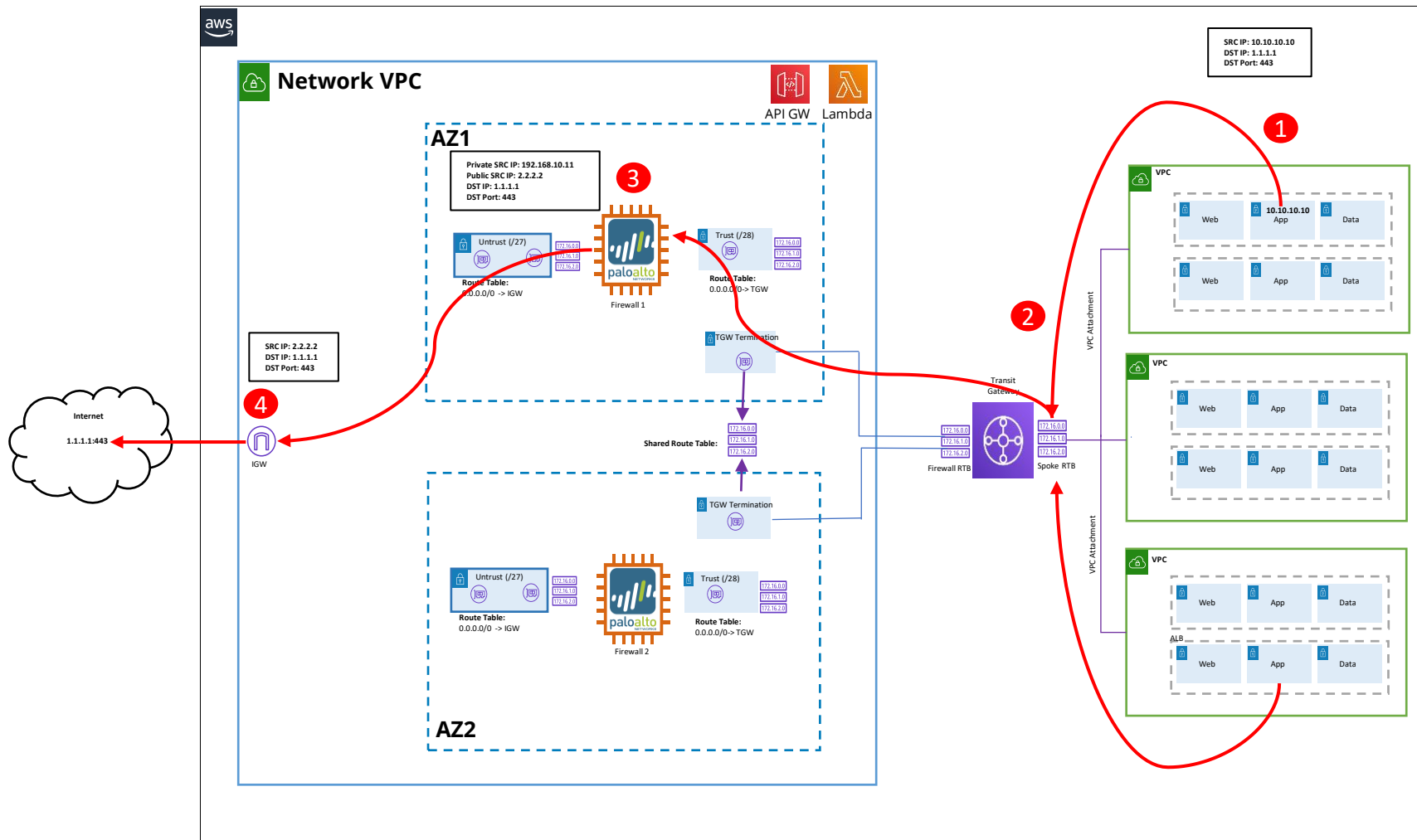

Exhibit 3-8

EDW-IMG-007.1

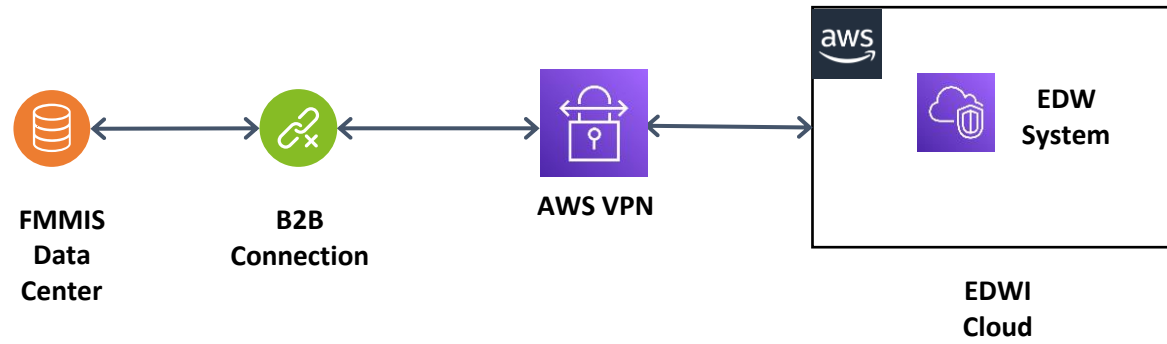

Exhibit 3-9

EDW-IMG-008.1

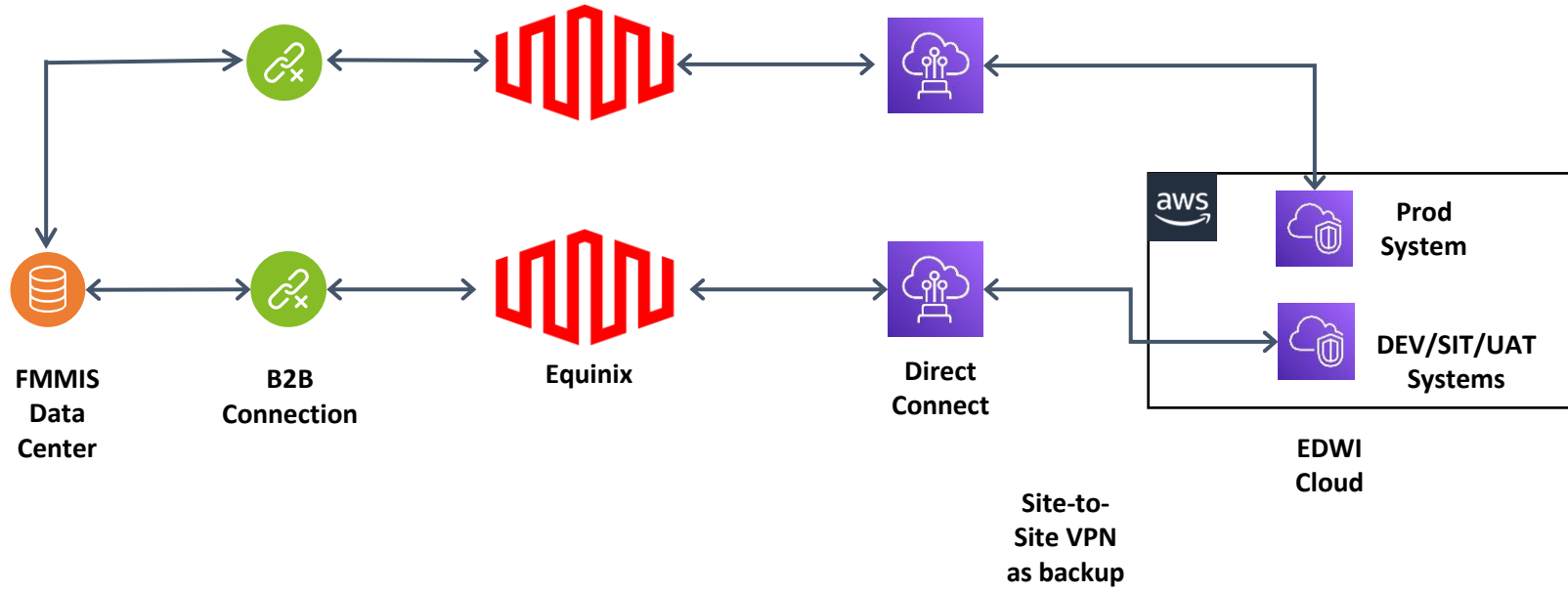

Exhibit 3-10

EDW-IMG-009.1

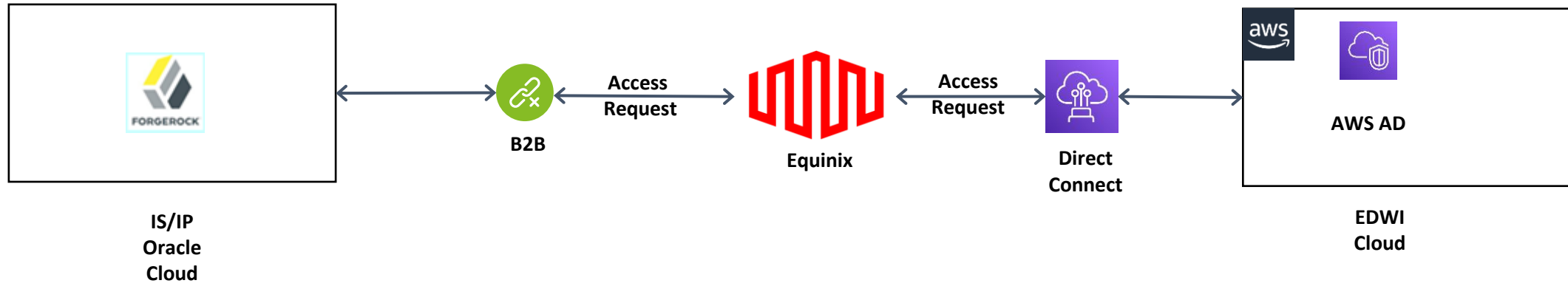

Exhibit 4-1

EDW-IMG-010.1

AWS DMS ×

- Dashboard
- Database migration tasks**
- Replication instances
- Endpoints
- Certificates
- Subnet groups
- Events
- Event subscriptions

What's new 10

Notifications

Database migration tasks (7) ↻ Actions ▾ Quick view and compare Create task

< 1 > ⚙

<input type="checkbox"/>	Identifier ▾	Status ▾	Progress ▾	Type ▾
<input type="checkbox"/>	aurora2oraclecdc	🔄 Load complete, replication ongoing	100%	Full load, ongoing replication
<input type="checkbox"/>	auroraoracle	✅ Load complete	100%	Full load
<input type="checkbox"/>	ongoingtest1	🔄 Load complete, replication ongoing	100%	Full load, ongoing replication
<input type="checkbox"/>	prodorapostgres	✅ Load complete	100%	Full load
<input type="checkbox"/>	productora2postgres	⏸ Stopped	100%	Ongoing replication
<input type="checkbox"/>	productora2postgres1tab	✅ Load complete	100%	Full load
<input type="checkbox"/>	viewmigrateoracle2post	✅ Load complete	100%	Full load

Exhibit 4-2

EDW-IMG-011.2

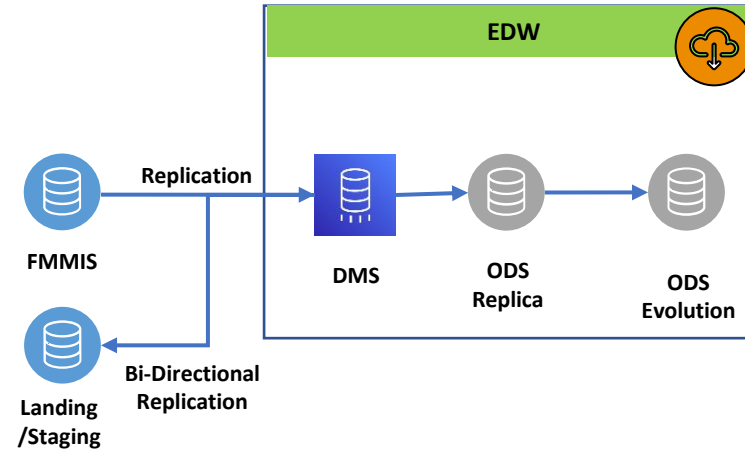

Exhibit 4-3

EDW-IMG-012.1

The screenshot displays a software interface for job management. On the left is a navigation pane with a list of jobs, including 'J_T_BUSNS_PRTNR_STAFF_NAME_BUILD_DS' which is highlighted. The main area is divided into three sections: 'Details', 'Job Runs', and 'Job Design'. The 'Details' section shows properties for the selected job, such as its name, short description, creation date, and last modified date. The 'Job Runs' section includes buttons for 'Stop', 'Reset', 'View Details', and 'Compare', along with a table for job runs. The 'Job Design' section shows a flow diagram with a warning message: 'The job design has been modified since it was last compiled. The image shows the most recent job design.' The flow diagram starts with 'Src_T_BUSNS_PRTNR' (Data Source), followed by 'Ink_Src_Out' (Ink), 'Rmd_Cols' (Transformation), 'Ink_Cols_Out' (Ink), 'lkp_BUSNS_PRTNR_ID' (Lookup), 'Ink_lkp_Out' (Ink), 'Chk_Src' (Check), and 'Ink_d' (Ink). A 'Ref' (Reference) icon connects 'lkp_BUSNS_PRTNR_ID' to 'Ref_BUSNS_PRTNR' (Data Source). Below the main flow, 'Ink_Rjct' (Ink) leads to 'Seq_Errorfile' (Sequence File).

Property	Value
Name	J_T_BUSNS_PRTNR
Short description	his Parallel job is to
Created	Administrator AppServer May 9, 2020 15:34
Last modified	Administrator AppServer May 9, 2020 15:34
Last compiled	Jul 2, 2018 19:31:12
Job type	Parallel
Multi-instance	No
Information Services enabled	No
Used by job(s)	1
Depends on job(s)	0

Job Run	Status
Started	Finished

Exhibit 4-4

EDW-IMG-013.1

The screenshot displays the IBM InfoSphere Information Governance Catalog interface. At the top, the header reads "IBM INFOSPHERE INFORMATION GOVERNANCE CATALOG" with navigation links for Search, Glossary, Information Assets, Labels, Queries, and Collections. The main content area is titled "PARALLEL JOB DETAILS" and features a job icon and the name "ADSLoad_NdcDimUpdate_Prl". Below the job name, the following details are listed: Project: MES; Purpose: This Parallel job update data into ADS2.T_NDC_DIM table from IDS2; Developer: Shweta Gadla; Creation Date: 28/02/2018; Modification: N/A; Defect or RFC Identifier: N/A.

A "CONTEXT" section shows the job is associated with "HIAPRODLIS01" and "dstage1". Below this, several expandable sections are visible: "Image", "Contains Stages or Containers (5)", "General Information", "Job Usage Information", "Job Design Information (6)", "Job Operational Information", "Lineage Information" (which is expanded), "Mapping Specifications", "Information Services Usage", and "In Collections".

The expanded "Lineage Information" section contains the following data:

INCLUDE FOR LINEAGE	True (Project)
LINEAGE SERVICE LAST RUN DATE	Jul 29, 2020 11:14:56 PM
LINEAGE SERVICE STATUS	SUCCESS
LINEAGE SERVICE INFORMATION	Undefined

Exhibit 4-5

EDW-IMG-014.2

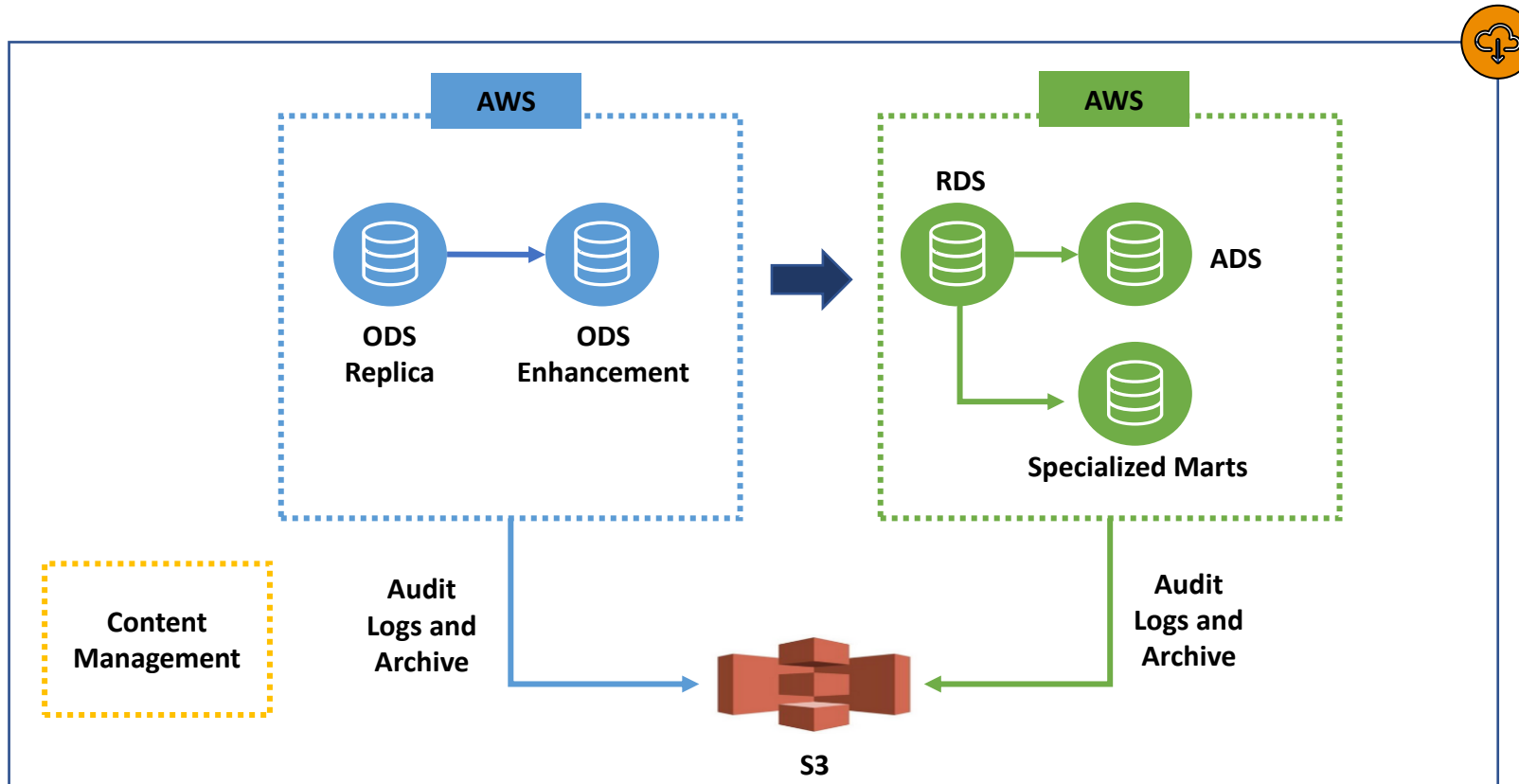

Exhibit 4-6

EDW-IMG-015.1

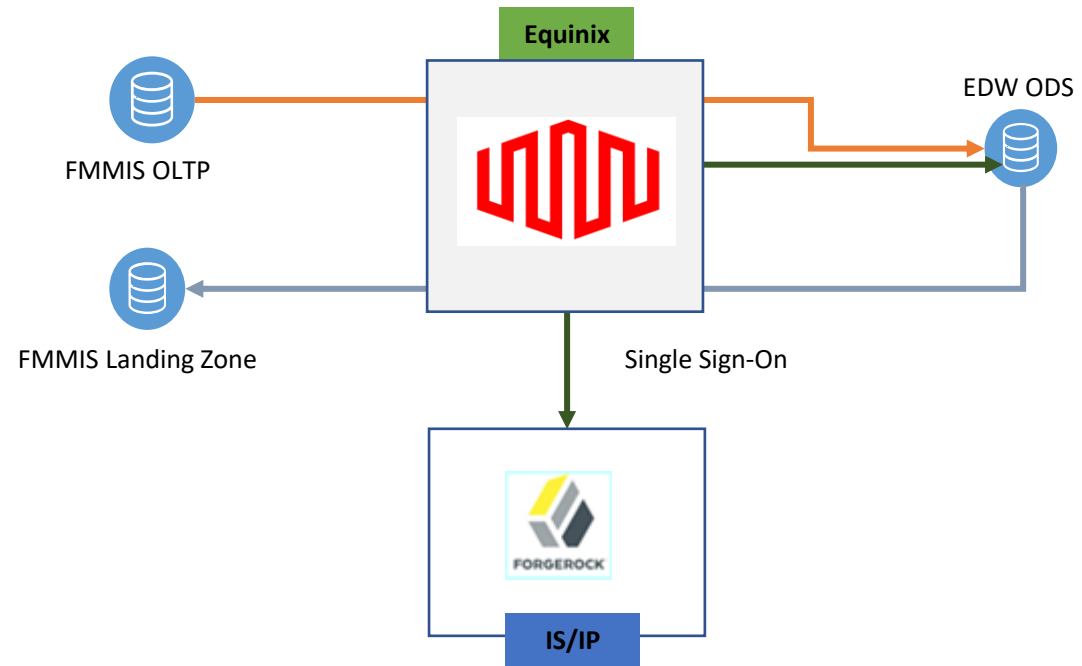

Exhibit 4-7

EDW-IMG-016.1

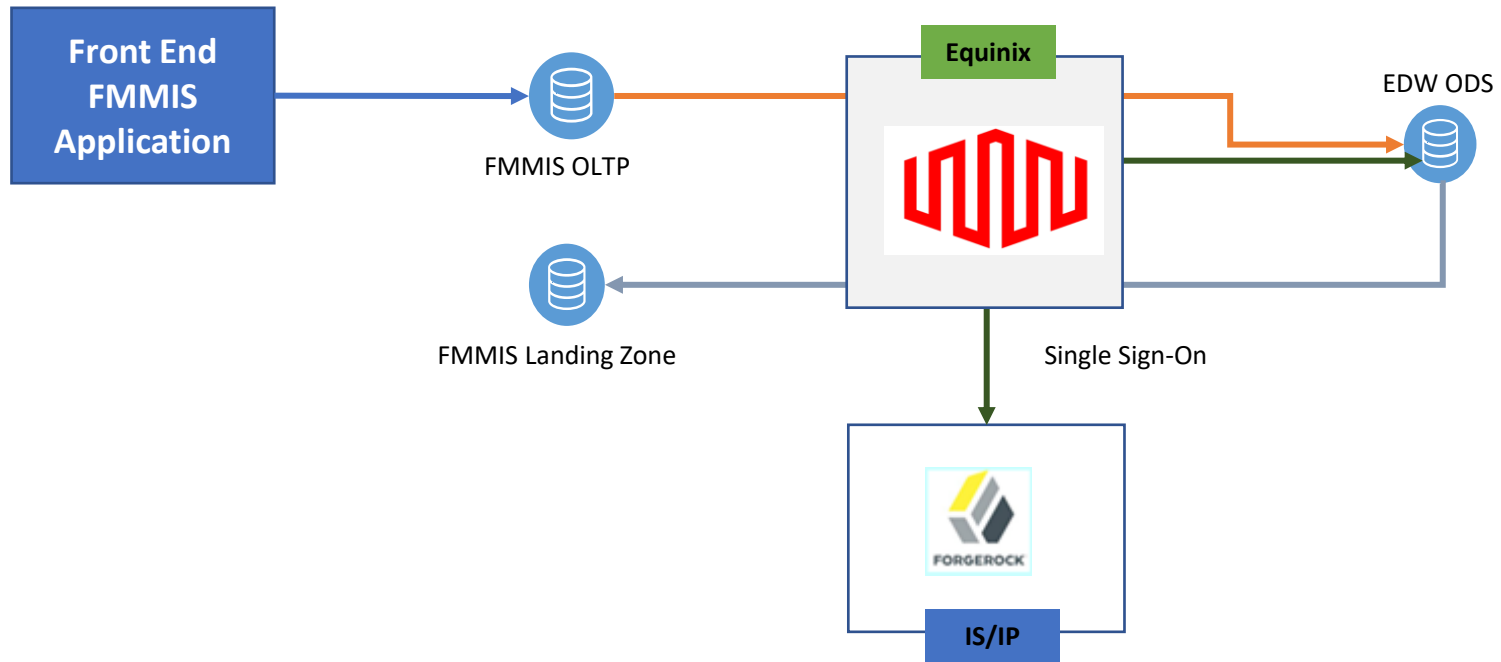

Exhibit 4-8

EDW-IMG-017.1

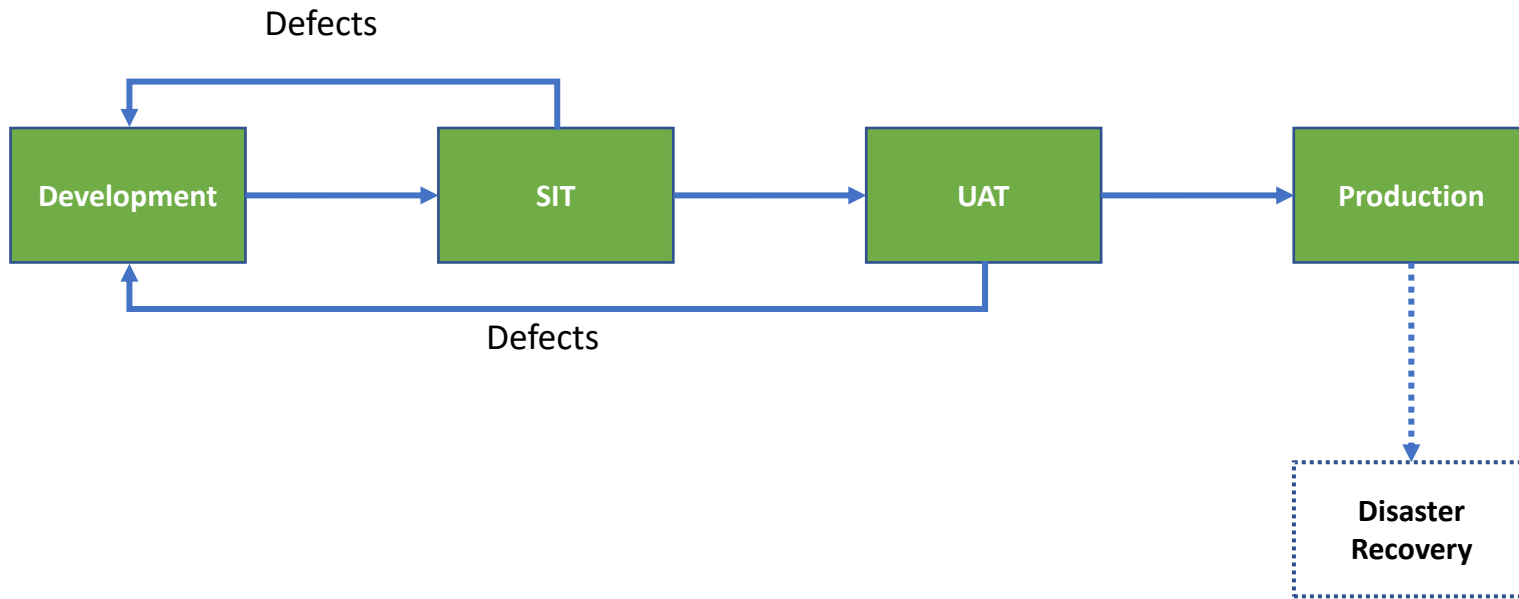

Exhibit 5-1

EDW-IMG-018.1

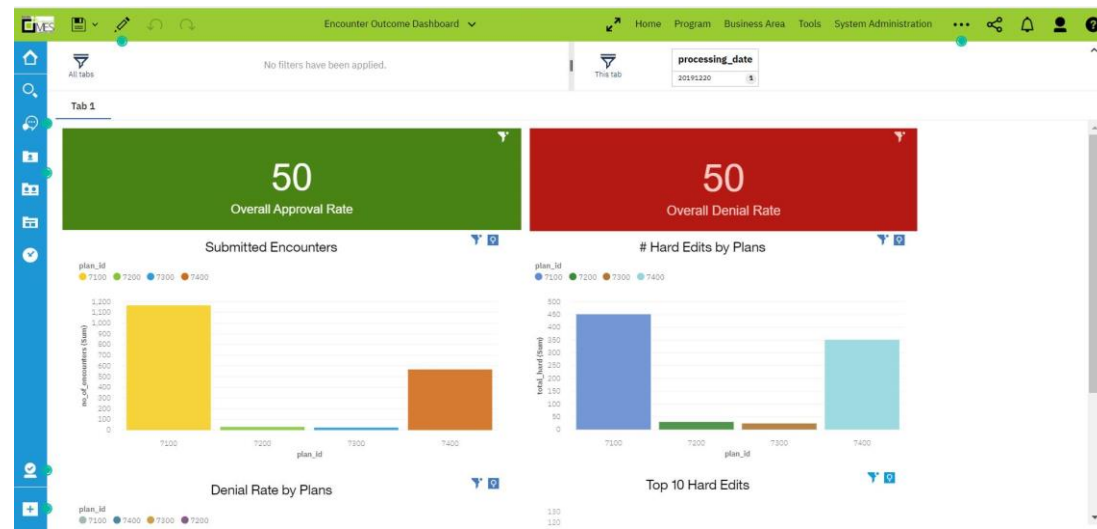





Exhibit 5-2







EDW-IMG-019.2

< Accounts

Find 

> AHCA   

All members

Name	Modified 
 Advanced Analyst	4/6/2021 5:31 PM
 Analyst	4/6/2021 5:31 PM
 Data Retriever	4/6/2021 5:32 PM
 Data Scientist	4/6/2021 5:33 PM
 Data Selector	4/6/2021 5:33 PM
 Data Viewer	4/6/2021 5:33 PM